

DATA CENTRE SOLUTIONS

EFFICIENCY, AVAILABILITY,
SCALABILITY AND SECURITY

CATALOGUE
PAGES
→ INSIDE

A GLOBAL PLAYER

The Legrand Group is a global specialist in electrical and digital building infrastructures. Having a workforce presence in 90 countries globally and a staff strength of more than 36 000 employees, Legrand is ready to respond to major market developments, as the Group continues to strengthen its position in the global markets.

LEGRAND DATA CENTRE OFFER

Our Data Centre solutions offer has been structured around four major pillars:

- Efficiency
- Availability
- Scalability
- Security

ENVIRONMENTALLY FRIENDLY SOLUTIONS

The Legrand Group strives to operate in an ethical, innovative, customer-oriented and sustainable manner in its day-to-day activities. Thus, Legrand attaches great importance to **Corporate Social Responsibility (CSR)**.



OUR 10 PRIORITY OBJECTIVES

- 1 Provide sustainable solutions
- 2 Play a driving role in the electrical sector
- 3 Act ethically
- 4 Ensure responsible purchasing
- 5 Enable access to electricity for all
- 6 Respect human rights
- 7 Guarantee health and safety at work
- 8 Develop skills and promote diversity
- 9 Reduce the group's environmental footprint
- 10 Innovate for a more circular economy

The LEGRAND GROUP

AN ACTIVE INTERNATIONAL PRESENCE

36,700 STAFF MEMEBERS THROUGHOUT THE WORLD

6.6 OVER BILLION IN TOTAL SALES IN 2019

SALES IN CLOSE TO 180 COUNTRIES

ESTABLISHED IN OVER 90 COUNTRIES

LEGRAND DATA CENTRE SOLUTIONS

The role of data centres is rapidly changing, being driven by the cloud and the growth in data. This has resulted in a reduction in IT costs. Significantly more dynamic activities are taking place in the data centre environment. This presents new challenges when it comes to designing and future-proofing data centre infrastructures.

Building a data centre demands a high degree of flexibility and a modular approach in order to be able to adapt to the ever-changing needs of the market. Projects are also becoming more and more complex due to increasing globalisation. Support and assistance from a well-informed, trustworthy partner is essential.

RELIABLE, EFFICIENT AND SCALABLE DATA CENTRE INFRASTRUCTURES IS WHAT WE CREATE

With award-winning solutions from Legrand, Cablofil, Raritan and Starline you benefit from optimal uptime of mission-critical operations. Our team of local specialists design and build innovative solutions including enclosures, cooling, power, structured cabling and access management to meet your unique requirements. Relied upon by thousands of organisations for over 30 years, Legrand Data Centre Solutions is your global partner to count on.

Digital INFRASTRUCTURE

POWERED BY SPECIALISTS



Legrand cabling systems for the white space currently provide high-quality connectivity to more than 200 million devices. The Legrand Group is a world leader in communication networks for data transmission. Its investment in the development and design of structured cabling systems and solutions has enabled it to expand its offer and achieve the highest level of performance.



Cablofil is the global benchmark for cable management systems, with cable tray systems that are not only packed with technical features but are also cost-effective. Cablofil is continuously inventing new solutions for electrical installations, to ensure optimum ventilation for power cables. Combining robustness and durability, Cablofil cable tray and P31 OFT systems provide optimum protection for cables whilst ensuring installations remain flexible and scalable in the data centres.



Raritan offers data centre power management solutions that include intelligent PDUs, transfer switches, environmental rack controllers and sensors as well as serial console servers and KVM-over-IP switches. In over 76 countries and 60,000 locations worldwide, Raritan's award-winning hardware solutions increase energy efficiency, improve reliability, and raise productivity.



Universal Electric Corporation (UEC), the manufacturer of StarLine, is built on over 90 years of innovation in delivering safe and flexible power to a variety of industries, businesses and institutions. Starline is the perfect solution for power supply in data centres with unique products that can be tapped instantly at any location. They can reduce downtime, as well as costs for expansion and new locations, while providing ongoing customisation and flexibility in power distribution.



Minkels is a knowledge-driven producer and worldwide supplier innovation of high-quality solutions for data centre infrastructures. Minkels products stand out for their innovativeness and flexibility. Customers can always be assured that they will get the very latest data centre technology: Modular solutions that respond to evolving, customer-specific business requirements.

YOUR BENEFITS

INCREASE YOUR ABILITY to scale according to your business requirements.

GET THE MAXIMUM from your existing & future IT equipment.

ADAPTED to all data centre use.

ENHANCE your data centre reliability.

OUR OFFER FOR YOUR KEY CHALLENGES

Combining relevance and reliability, our dedicated data centre solutions allow you to satisfy the most demanding requirements, particularly in the area of cooling, power, availability and security.



EFFICIENCY

- Reduce the carbon footprint of a data centre
- Improve power usage effectiveness
- Reduce power losses



AVAILABILITY

- 100% Business continuity
- System redundancy
- Guaranteed continuity of service



SCALABILITY

- Optimisation based on current and future needs
- Future proof your installations
- Modularity for quick adaptation to changes



SECURITY

- Protect your equipment (including the data in it) against intrusion
- Safe operation and detection of internal/external environmental events (fire system, environmental sensors - water leakage, flooding, overheating, vibrations, lighting)
- Ensure the safety of people working in the data centre

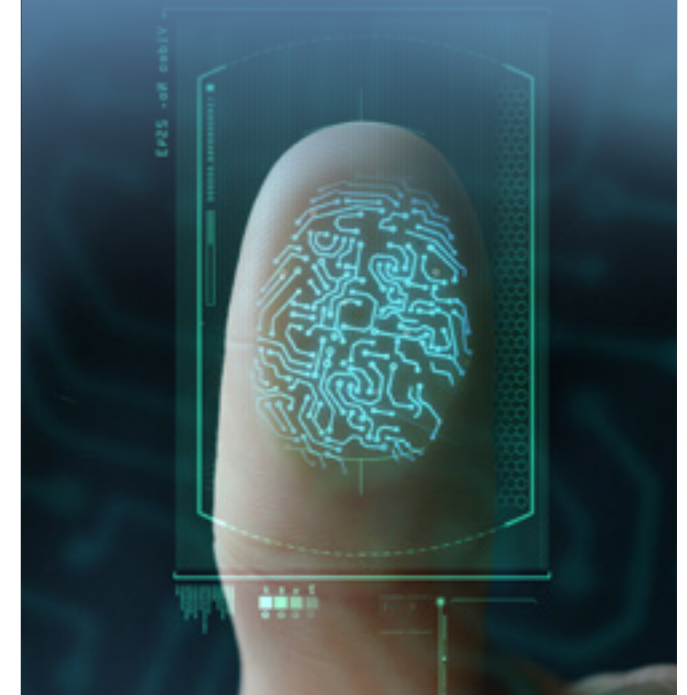

LEGRAND DATA CENTRE

Solutions in the GREY SPACE

SAFEGUARDING POWER QUALITY, MONITORING AND ENHANCING EFFICIENCY

The technical room, an essential part of the data centre, must be dimensioned to distribute and protect a building's entire electrical infrastructure, right up to the servers, yet still take account of energy quality and lower energy consumption considerations.

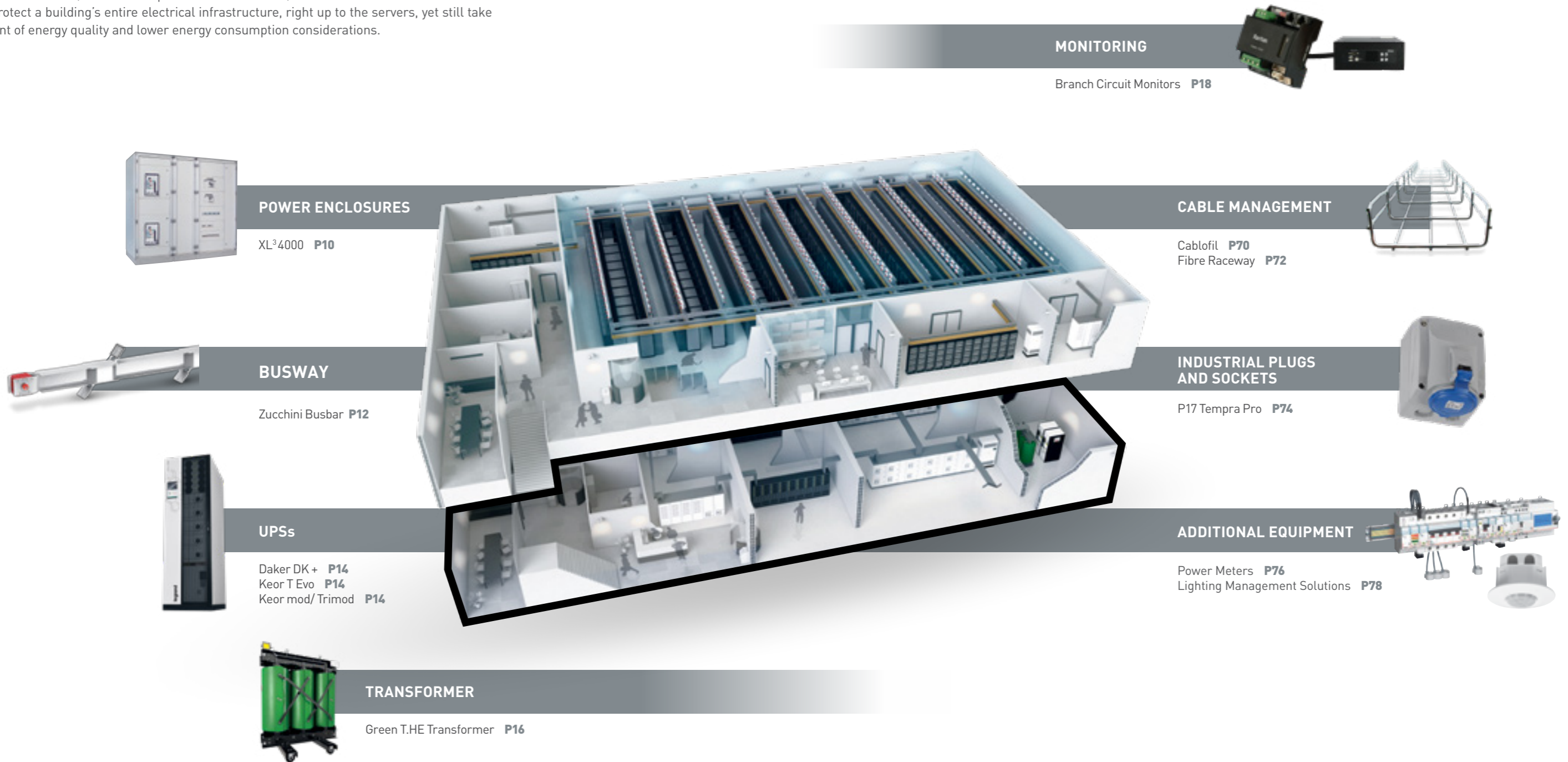

MONITORING

Branch Circuit Monitors P18



POWER ENCLOSURES

XL³4000 P10



CABLE MANAGEMENT

Cablofil P70
Fibre Raceway P72



BUSWAY

Zucchini Busbar P12



INDUSTRIAL PLUGS AND SOCKETS

P17 Tempra Pro P74



UPSs

Daker DK+ P14
Keor T Evo P14
Keor mod/ Trimod P14



ADDITIONAL EQUIPMENT

Power Meters P76
Lighting Management Solutions P78



TRANSFORMER

Green T.HE Transformer P16



Power Enclosures

XL³ 4000A



For safe and comfort compliant installations

The Legrand XL³ range was designed to meet the needs of all power distribution requirements up to 4000 A.

From XL³ 125 up to XL³ 4000, all the enclosures provide optimum performance and easy installation.

XL³ enclosures are divided into four ranges according to the maximum current-carrying capacity: XL³ 125, XL³ 160, XL³ 400, XL³ 800 and XL³ 4000.

Each one is available in a wide range of sizes and versions (insulated, metal, IP30, IP55).

DPX³ MCCBs

Protection and accurate measurement up to 1600 A.

Suitable for all types of site, the DPX³ range includes 4 sizes of MCCB, for ratings between 16 A and 1600 A and breaking capacities ranging from 16 to 100 kA.

It also offers a wide choice of versions to suit all requirements: Thermal-magnetic or electronic releases according to the required level of protection- Fixed, draw-out and plug-in devices according to the required level of maintenance.

FOR SAFE AND COMFORT COMPLIANT INSTALLATIONS

Complies with AS/NZS 61439



DMX³ ACBs

From 630 A to 6300 A, breaking capacities (42 kA, 50 kA, 65 kA and 100 kA) and 4 sizes (fixed or draw-out version).

DMX³ air circuit breakers and DMX³-I isolating switches offer great flexibility and are suitable for all requirements.

Its unique depth common to sizes 2500, 4000 and 6300 simplifies enclosure configuration and busbar connection.

Busway

Zucchini Busbar up to 6300A

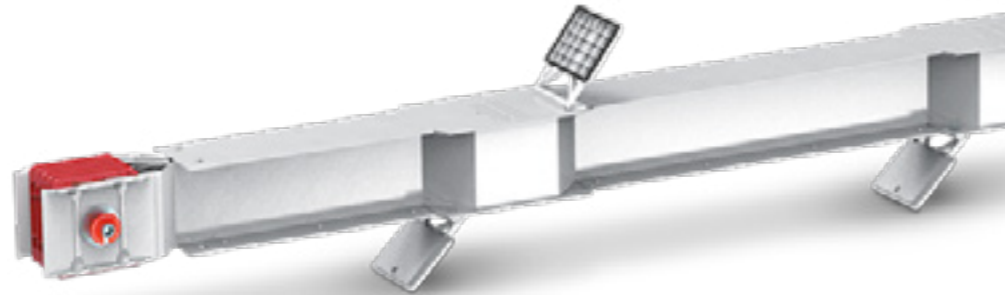

Straight elements

XCP includes all the necessary components to enable any path for the busbar run that the project requires. The straight elements are available in versions for transport and distribution (with tap-off outlets) of high-power energy.

XCP - HIGH POWER BUSBARS

Elbows

Suitable for making changes of direction, available in standard or special version. Supplied with junction monobloc preassembled in the factory



Feed units

They allow to electrically feed XCP and are available in standard version or as a variant for vertical power lines, riser mains lines

Connection interfaces with exit bars

Element used at the end of the lines to connect the busbar to boards or transformers



RCP - IP68 RESIN BUSBARS

RCP

RCP IP68 with range from 630 A to 6300 A, is a complete product that includes the most useful shapes to adapt to the clients and project requirements. What is more RCP IP68 is completely compatible with the SCP IP55 product. The typical applications of IP68 busbar trunkings are:

- Outdoor (in different extreme conditions)
- Industrial plants
- Petrochemical plants
- Chemical plants
- In areas with risk of flooding



Elbow

Available in various versions (horizontal, vertical, single, double)

Connection interface

Component used at the ends of the lines to connect the busbar to electric distribution board or transformers

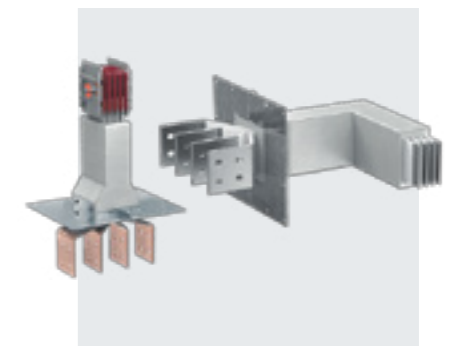

Suspension bracket

Enable sturdy installation of the busbar to the system support structures

UPSs

Daker DK +, Keor T Evo, Keor mod/Trimod

UNINTERRUPTIBLE POWER SUPPLIES (UPS)

There are 3 types of UPS, depending on the technology of their design:

- single UPS
- distributed (or centralised) parallel UPS
- modular UPS

UPS, with optimised energy efficiency, ensure the power demand is as close as possible to the actual requirements and reduce power losses. In fact, if the efficiency of the UPS is increased, it will give off less heat, which will reduce cooling and consumption losses.

Legrand offers UPS solutions that can achieve **efficiency levels of up to 96%** mode Online (VFI - Voltage Frequency Independent double conversion).



Types of UPS to use in different data centres:

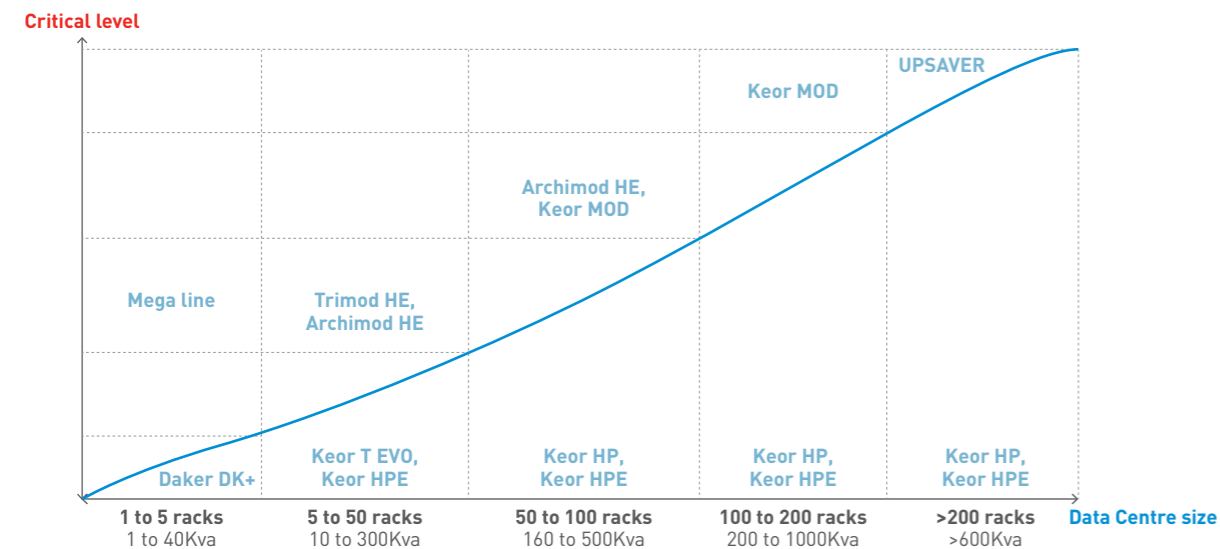

Mean time to repair < than 10 min

Making an installation scalable without any loss of capacity involves above all choosing solutions that provide a modular architecture which guarantees optimum performance in all circumstances



“Hot Swap” system

This system enables components to be added or replaced in an installation while energised, without any interruption to the system and with no risk of damaging the rest of the installation

UPS solutions up to tier 4

The data centre is assigned a tier according to the required availability. This ensures a certain level of continuity of power supply and service. The tier classification classifies data centres according to the degree of reliability and availability of data in accordance with standard ANSI/TIA-942 and the Uptime institute certification

MINIMUM RECOMMENDED TIER/CLASS ACCORDING TO THE SIZE OF THE DATA CENTRE

TIER /CLASS >	1	2	3	4
ENTERPRISE		OK		
CORPORATE			OK	OK
COLOCATION			OK	OK

EFFICIENCY LEVELS UP TO 96%* with Legrand's UPS

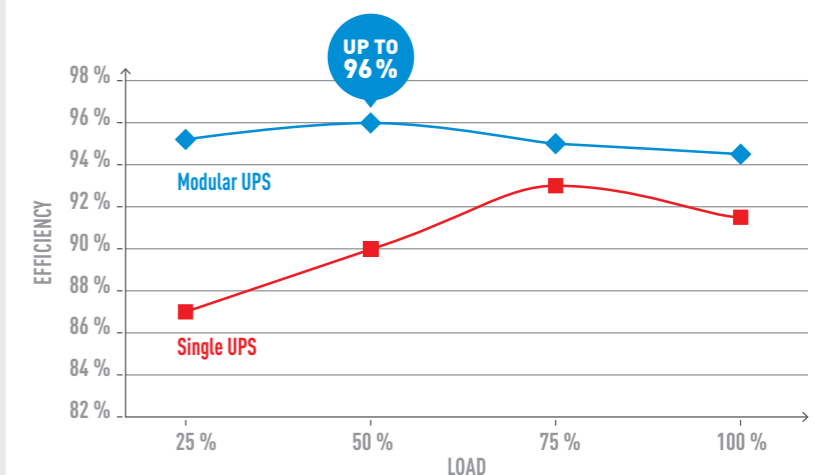

* Mode Online (VFI - Voltage Frequency Independent double conversion).

Transformer

Green T.HE Transformer



Thanks to experience in the production of cast resin transformers (up to 36KV) and constant investment in R&D, Legrand provides high quality products.

THE RELIABLE ANSWER FOR DISTRIBUTION, RECTIFICATION AND SPECIAL SOLUTIONS

- Compliant with the EN 50588-1 standard
- Lower energy consumption
- Decrease of CO₂ emissions
- Economic savings
- Excellent performance in a wide range of applications

The classification of a cast resin transformer is referred to the value of the no-load losses (P₀), as well as the load losses (P_k).

P₀ losses are independent from the load and they remain constant for the entire period when the transformer is connected to the electric power network.

P_k losses occur only when the transformer is connected to a load and they are proportional to the square of the current.

NO-LOAD LOSSES (P ₀)	LOAD LOSSES (P _k)
A ₀	A _k
A ₀	B _k

Certifications

Cast resin transformers have been designed and manufactured according to the provisions laid down by the main national and international standards and certified by the following certification body:



High security

- Low fire hazard - manufactured entirely with flame retardant and self-extinguishing materials
- Designed to withstand the most severe conditions
- Possibility of installation inside buildings

Easy installation & maintenance

- No expensive civil works such as fire resistant separation barriers
- Standard periodic maintenance only
- Easy integration with Zucchini Busbar systems



Energy efficiency

- Comply with the EN 50588-1 standard.
- Designed and manufactured according to the Regulation 548/2014
- Low CO₂ emissions

Low environmental impact

- High quality opacy resin - for minimum environmental impact
- No risk of insulating fluid losses
- Low CO₂ emissions
- Possibility of retrieving end-of-life materials
- Conform to use international environmental standards IEC 60076-11



Distribution and special solutions

Monitoring Branch Circuit Monitors

RARITAN'S INTELLIGENT BRANCH CIRCUIT MONITORING (BCM)

This system allows you to fully utilise your power infrastructure and manage capacity as your data centre grows and changes. Whether you are retrofitting an existing facility, or planning for growth or new construction, Raritan's BCM system can help you reduce energy costs, track power usage, and prevent downtime. Easily add metering where it never existed before.

This easy-to-deploy modular system, enables real-time views of electrical capacity and power usage on branch circuits, and mains, in an electrical service entrance or a remote power panel. It sends threshold alerts for power and environmental conditions, thereby helping to prevent downtime. The data can also support energy efficiency and customer charge-back initiatives, cooling and consumption losses.



Features

- Meters Floor PDU, RPPs, Panelboards, and Busways
- Auto-correct metering adjusts for CT orientation on wires
- Several enclosure options
- Collects data on: A, V, kW, kVA, power factor, and kWh
- Protocols include TCP/IP, Modbus and SNMP

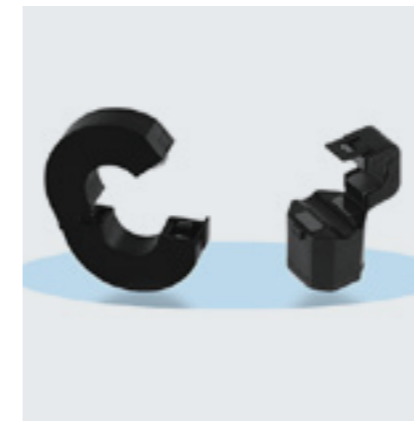
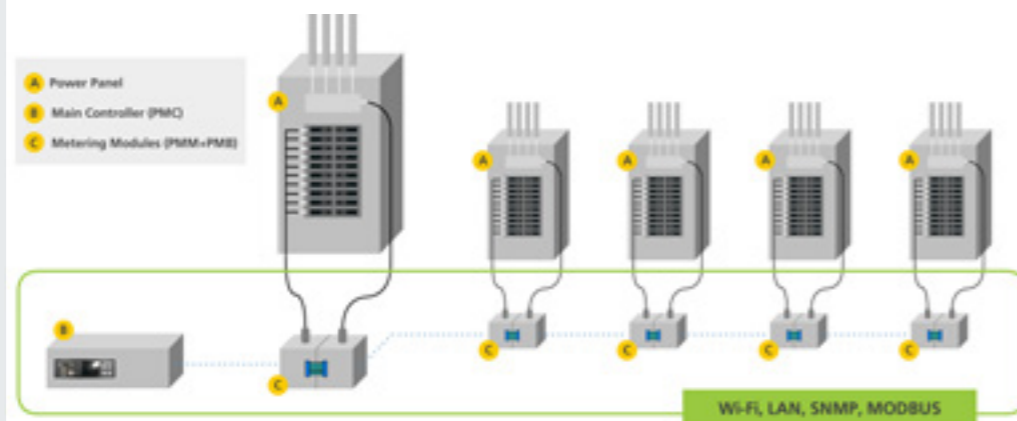

Auto correcting split type CTs for fast & easy installation

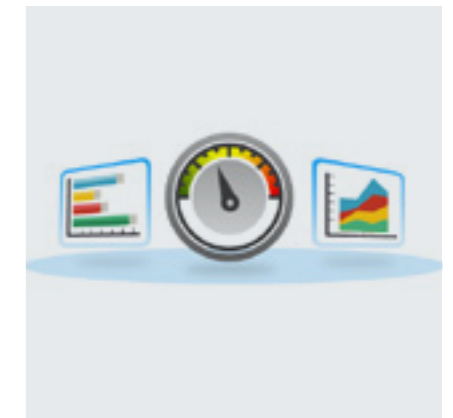

One of the most accurate metering solution in the market

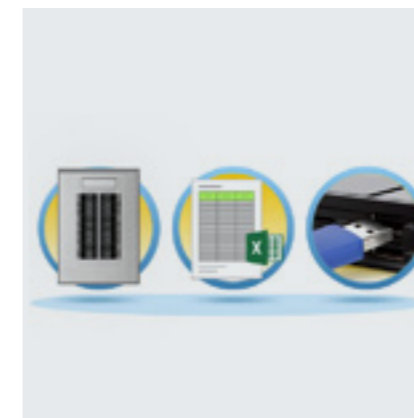

Real-time configurator for quick setup

Best design for existing installation upgrade

LEGRAND DATA CENTRE

Solutions in the WHITE SPACE

RELIABLE, EFFICIENT AND SCALABLE DATA CENTRE INFRASTRUCTURES IS WHAT WE CREATE

Legrand Data Centre Solutions offers sustainable data centre solutions. The key concepts of **modularity, flexibility and energy-efficiency** have been implemented throughout the extensive product portfolio. This ensures that customers always benefit from the latest data centre technologies with modular solutions that are flexible and fully adapted to the ever-changing needs of the data centre infrastructures.

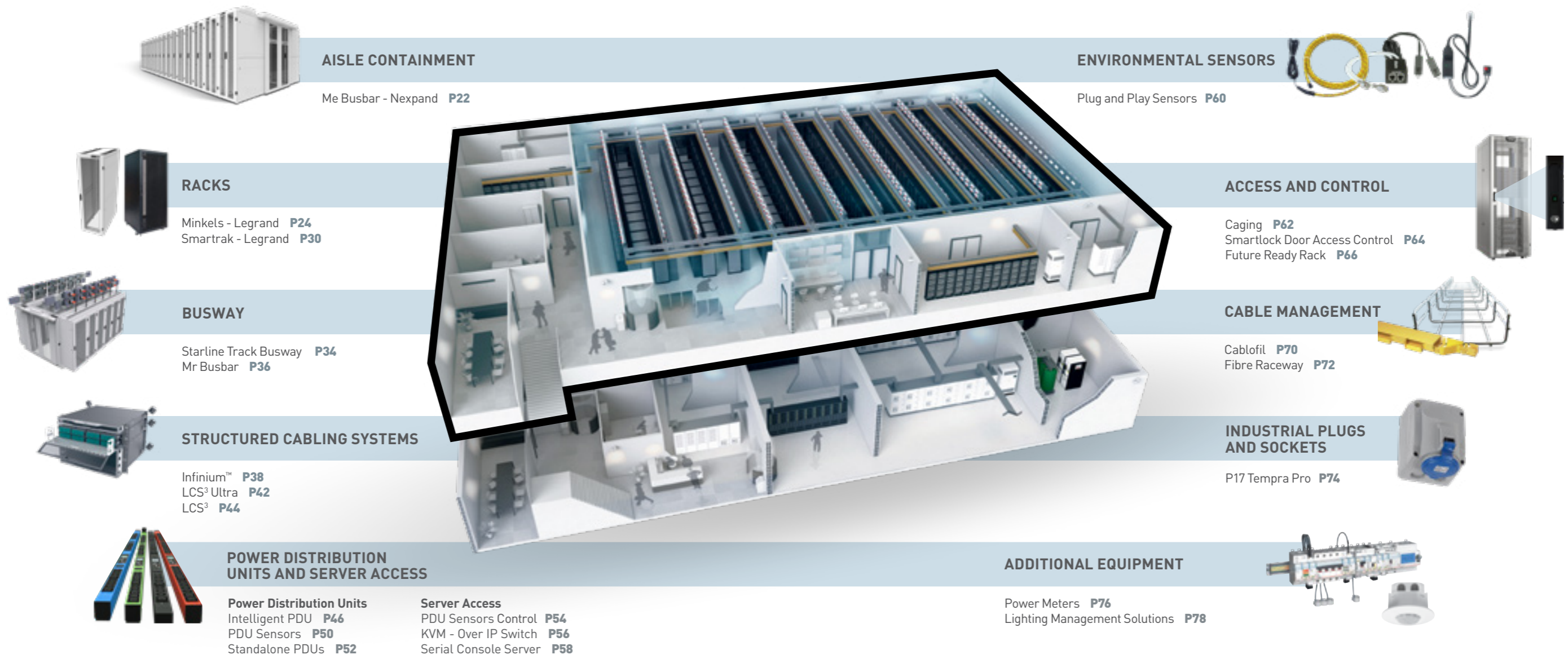

Aisle Containment



NEXPAND

Aisle containment is the solution to the challenges which data centres are presented with. The optimisation of cooling and energy-efficiency through the separation of hot and cold airflows.

With the **Nexpand Corridor**, Minkels offers data centre managers and owners 'future-proof' solutions. This offers the flexibility and modularity needed to be able to anticipate the dynamic of the modern day data centre. Minkels offers the best solution for every situation with the Nexpanse Corridor.

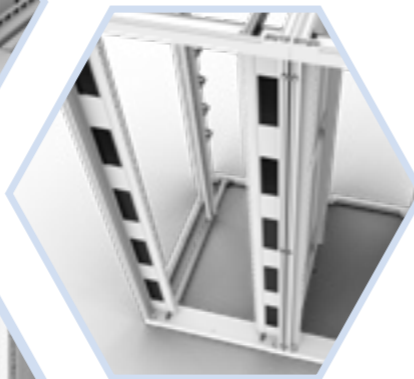

The Nexpanse Corridor is the ultimate answer to the ever increasing demand for flexible and modular solutions. In the form of the Nexpanse Corridor, Minkels lifts modular thinking and energy-efficient data centre design to the next level.

IMPORTANT NEXPAND CORRIDOR FEATURES:

Modularity

Through the highly modular concept of the Nexpanse Corridor, Minkels offers extensive possibilities to implement a Corridor solution in a phased and thus cost-efficient manner.

Flexibility

Because of its modular design, the Nexpanse Corridor is flexible and thus can be adapted to fit the specific building environment.

Ease of installation

Modularity in the construction details ensures that the solution is easy to install and cost efficient.

Energy-efficiency

With the Nexpanse Corridor, Minkels offers a solution which is more energy efficient than other containment solutions on the market.

Optimal integration

The Nexpanse Corridor can be integrated with row-based cooling systems which brings cooling close to the heat source, but also with more traditional forms of cooling which require a raised floor. In addition, this concept offers plug & play integration with fire detection and suppression systems, monitoring sensors and access control.

Corridor - Standard			
Aisle width	mm	Variable between 1000-1800 Standard width: 1200 & 1800	
Overall width	mm	Aisle width + 200	
Standard row height	mm	1978/2200/2422	
Overall height	mm	Row height + 55.5/135.5 (Hr)	
Colours		RAL 9003 (white) / RAL 9005 (black)	
Materials		Powder coated sheet metal	
Working conditions		Max. 5 - 40°C / 20 - 80% RV	
Standardisation		CE	

Portal - optional			
Depth	mm	100	
Total width portal	mm	2100	



Watch all the features
www.minkels.com/videos/nexpand

Racks

Minkels rack

Nexpand features

FRAME

- Light and solid aluminium frame with the capability to handle 1500 kg of static load
- Offers unique flexibility through stepless mounting possibilities in all three dimensions of the cabinet
- Threaded mounting rails in width, depth and height direction enable stepless adjustability (for example cable management)
- Integrated T-slots provide stepless adjustability in depth and width direction (for example vertical mounting rail adjustment)
- Nearly all accessories and components accessible from inside of the cabinet
- The cabinet is ready for placement of slide-in-side panels. This feature provides separation of cabinets, even after the cabinets are already installed and bayed
- Upgrade the energy efficiency by adding an airflow package at a later stage is possible

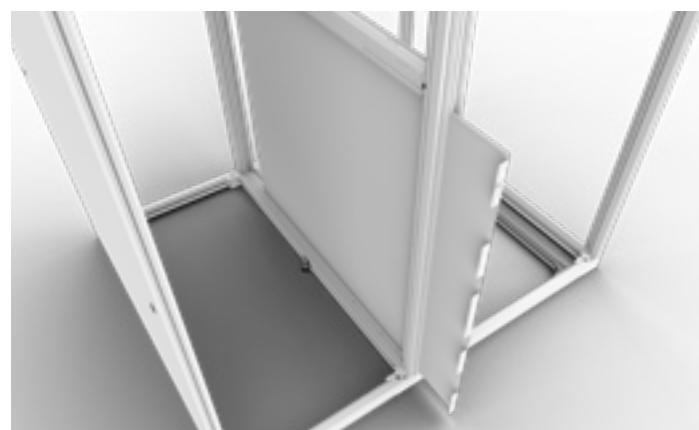

Slide-in side panel ready

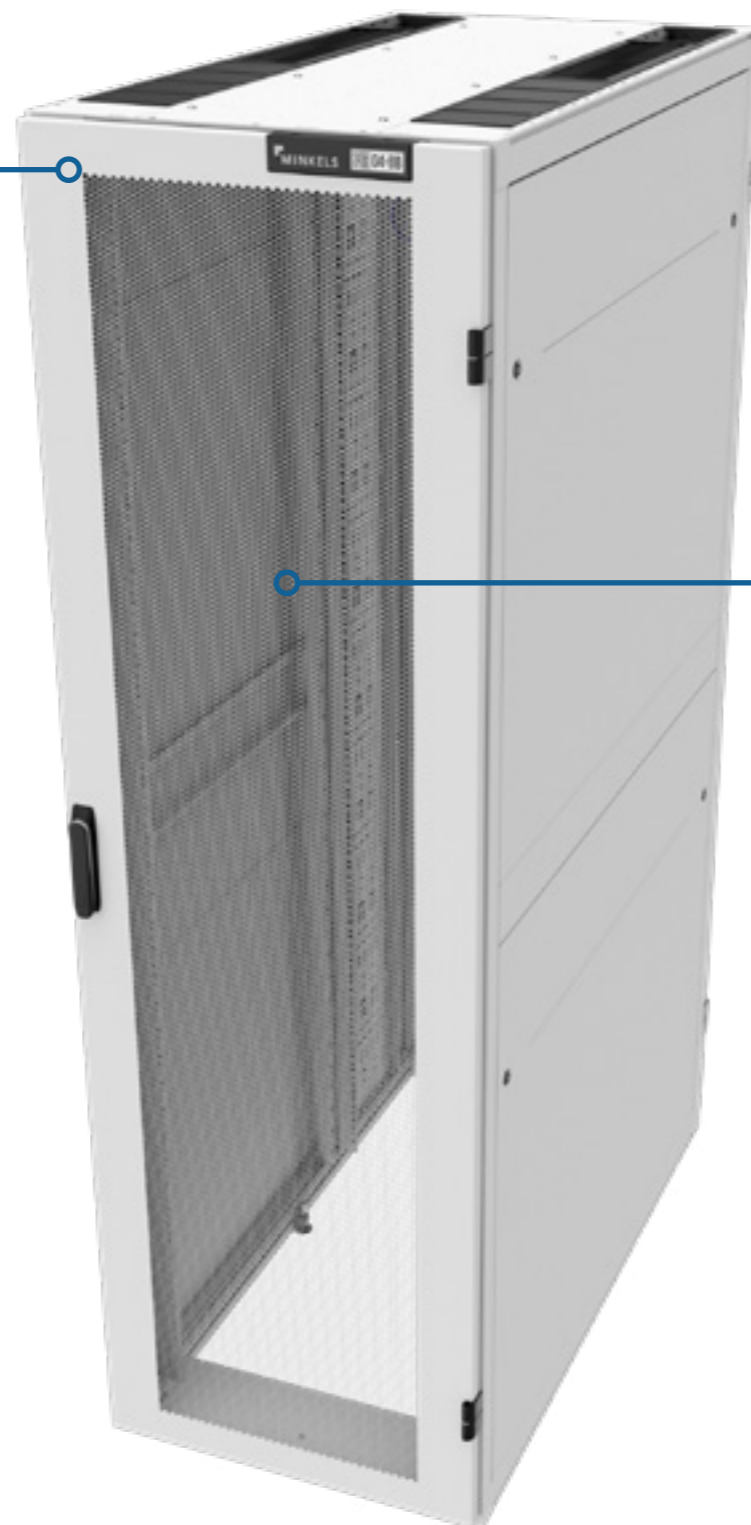

Depth marking placed on depth profiles
Stepless adjustability in depth direction

DOOR

- Predefined position for identification
 - Place serial numbers, barcodes or QR codes to code and personalise your cabinets
- Clean and minimalistic design
- Easy door installation
- High level perforation
- Full integration of the locking mechanism and cabling (in case of smart lock)
- High level access security
- Support of different types of locking possible
- Replacement of locking through detachable cover plate rear
- Door easily reversible (left/right hinged)
- Door can open 165° in case of bayed cabinets
- Door can open 260° in case of stand-alone cabinets

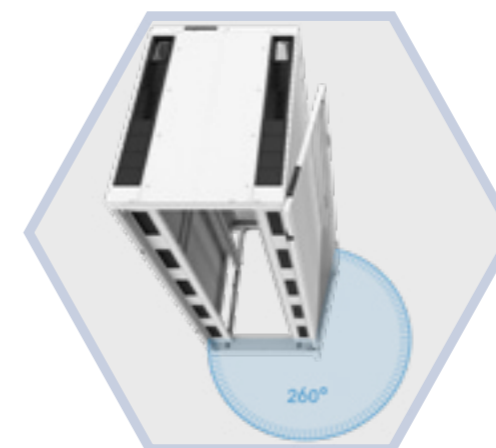

Racks

Top-of-Cabinet

EASY MAINTENANCE

These days, cabling and power distribution is organised on top of the network or server cabinet. By placing this in a more accessible and visible location, the accessibility of the cabling and power supply increases. In this way, it's easier to maintain and make changes to cabling and power distribution than it would be if the cabling was located under the cabinet.

FLEXIBLE ROOF LAY-OUT

The roof lay-out has been improved considerably, for example with respect to the positioning and the surfaces of the openings located on the top of the cabinet.

The mounting rails are implemented on the top of the cabinet. These mounting rails enable flexible adjustability of accessories, brackets and all possible forms of cable management that can be placed around the entire perimeter across the width and depth of the cabinet.

POWER DISTRIBUTION ON TOP-OF-CABINET

In addition to the fibre optic and copper cables, the power distribution can also be placed on top of cabinets. A power distribution unit is usually placed on the back of the cabinet to connect all the IT equipment to the mains. Top-of-cabinet enables power distribution through cabling and busbars.

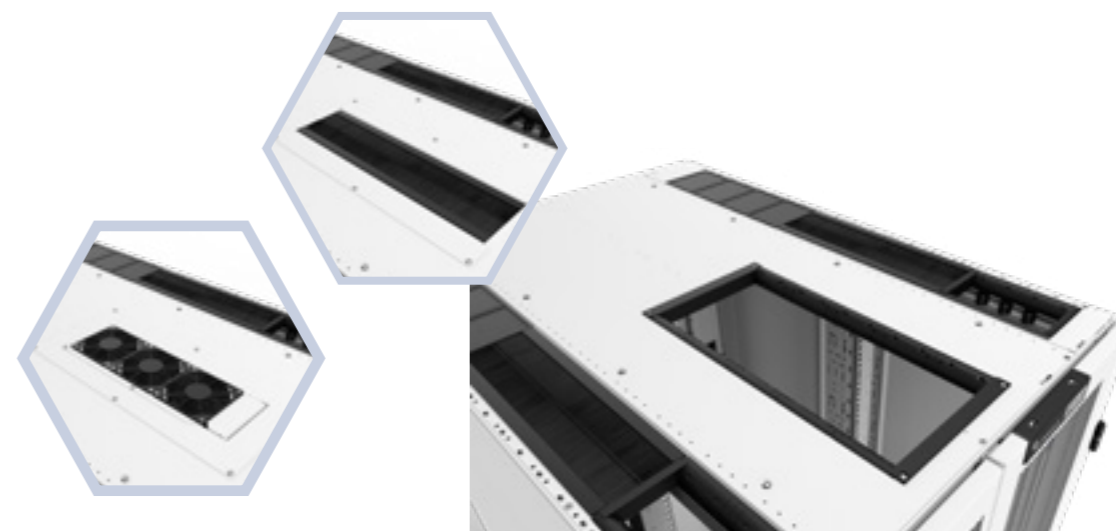

Extra cut-out in the middle for (high-volume) cable management, brushes or fan-unit

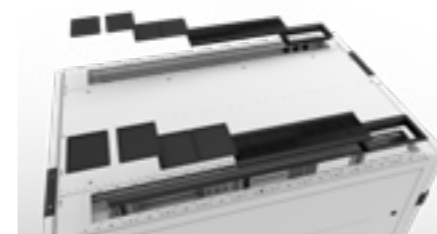

Nexpand features

ROOF

- Solid platform for installation top of cabinet infrastructure
- Roof inserts follow a multiple of 100 mm
- Nearly full-depth cut-out
- Optimal accessibility for cabling
- Optimal positioning for PDU's
 - Up to 32A plugs shall fit
- Cable pull relief available
- Cable dividers on top of cabinet follow the same modularity as the inserts
 - Extendable per cabinet to create a cable duct system
 - Cover plates and end covers available for dust/debris protection and airtight solutions
 - Powder coated in same color as cabinet
- Roof is compliant with hot/cold aisle containment

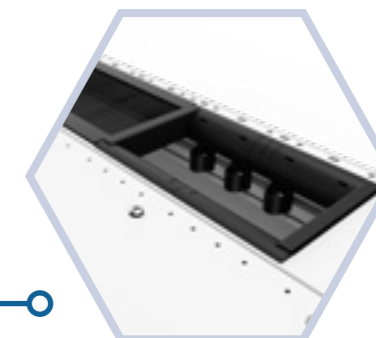
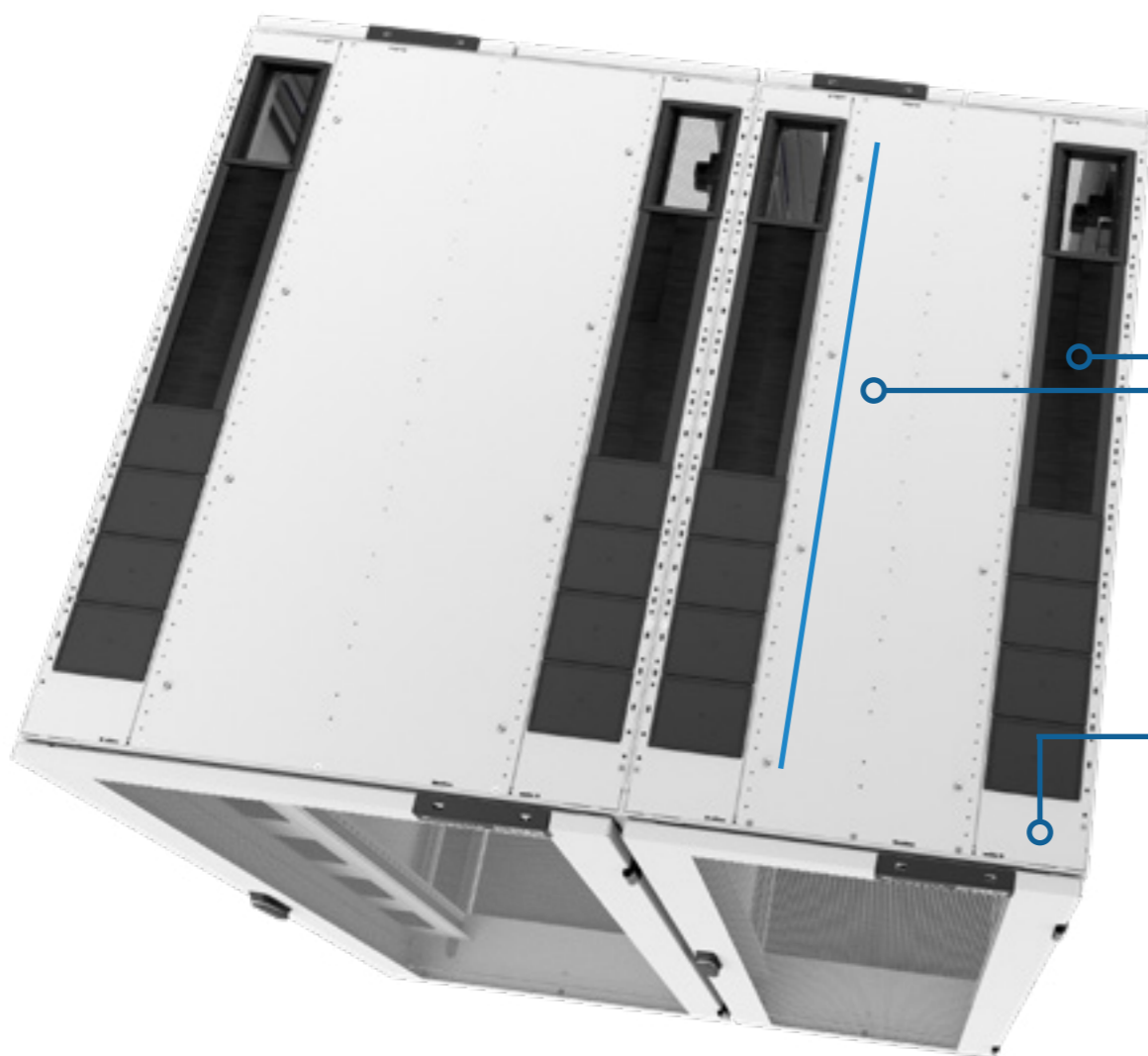

Racks

Accessories

Nexpand features

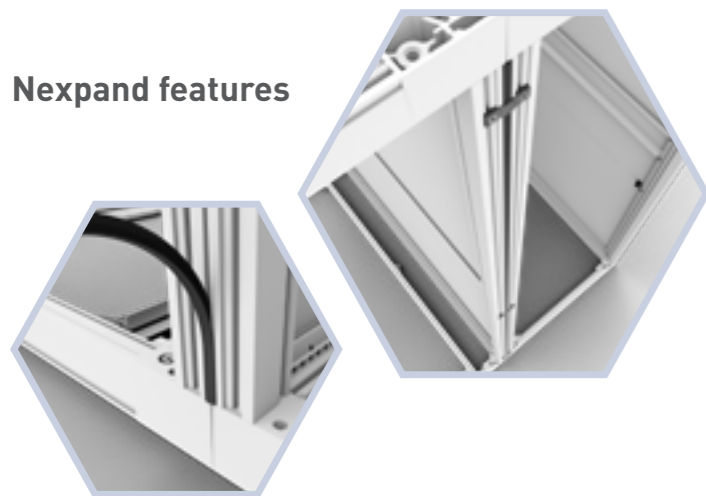

SERVER CABINETS WITH AIRFLOW MANAGEMENT PACKAGE

- Best in class air tightness
- Keep flexibility in adjusting vertical mounting rails without compromising on air tightness
- Upgrade the energy efficiency by retrofitting an airflow package
- Sealing cabinet-to-cabinet is optional
- Sealing cabinet-to-floor and cabinet-to-aisle containment is optional

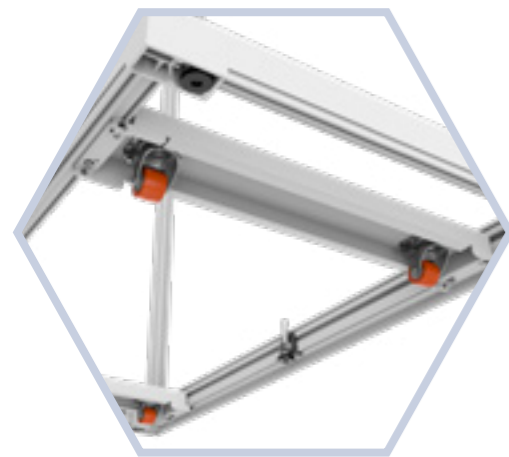

Transport castors available

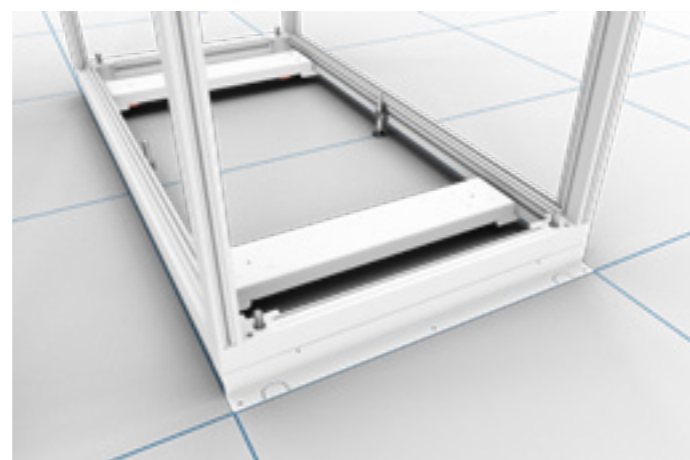

Easy floor tile alignment due to reversible plinth

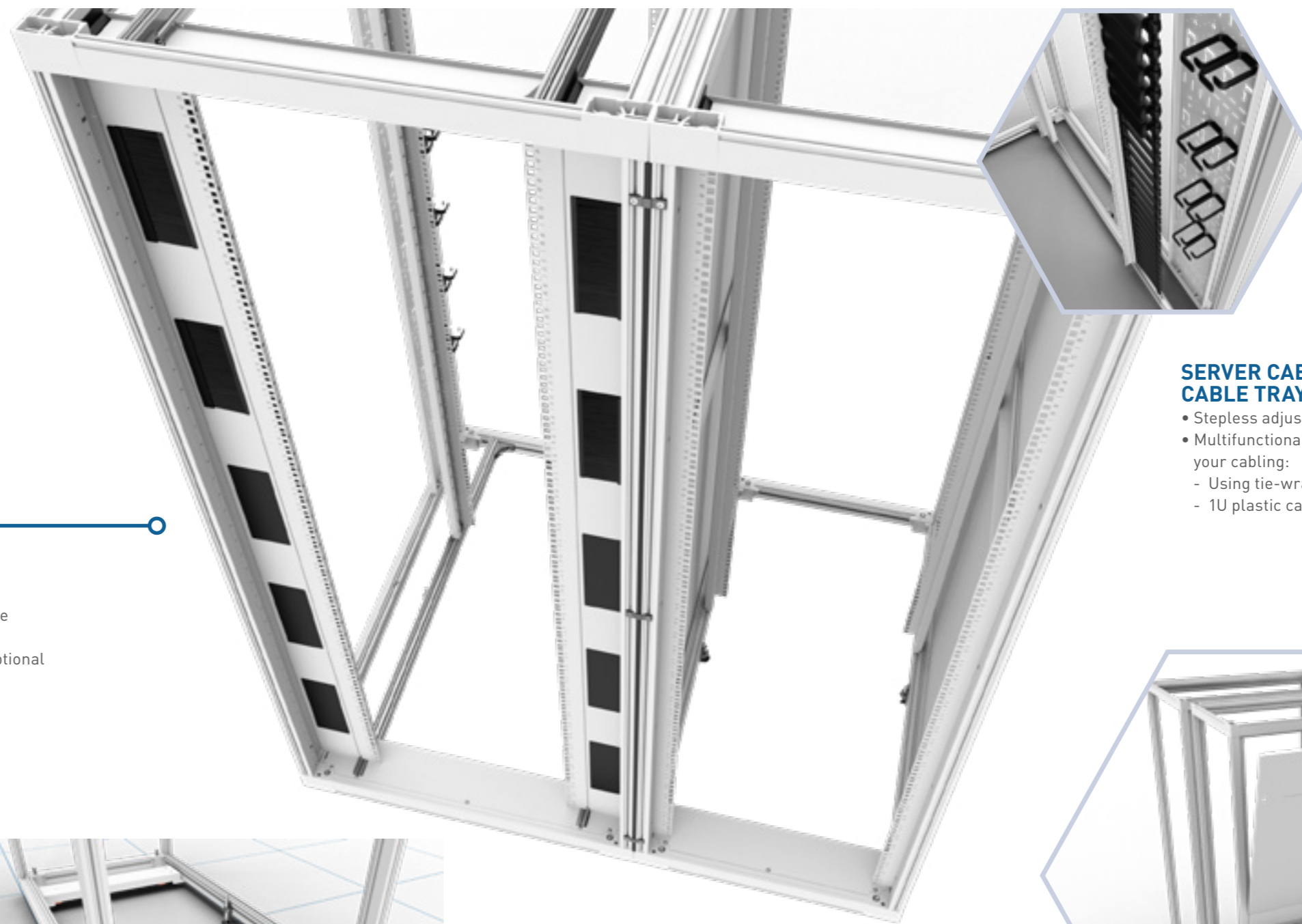

SERVER CABINETS WITH CABLE TRAY

- Stepless adjustability in depth direction
- Multifunctional cable tray to organise your cabling:
 - Using tie-wraps and/or Velcro
 - 1U plastic cable ring, toolless mount

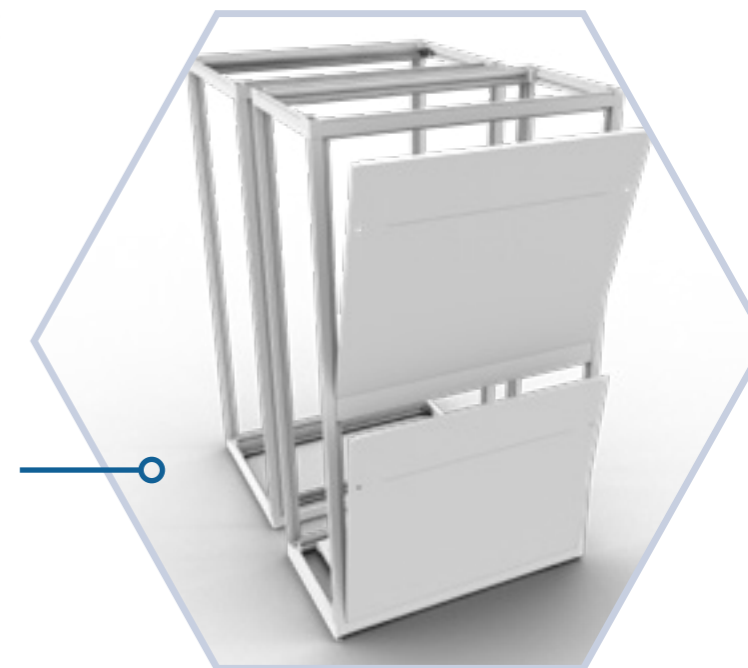

SERVER CABINETS WITH SIDE PANEL

- Side panels are used when stand-alone is preferred or when the cabinet is placed at the end of the row
- Earthing connection is established when locking the panels
- Horizontally divided panels for easy handling

Racks

Legrand SmartRack

Cost effective, efficient and reliable server rack system

Features & benefits

- Static load rating of 1200KG.
- Full height door for better ventilation.
- 3 times bend panel mounting for a stronger structure
- Save assembly time with flat packs with the new simplified design with lesser parts to fix

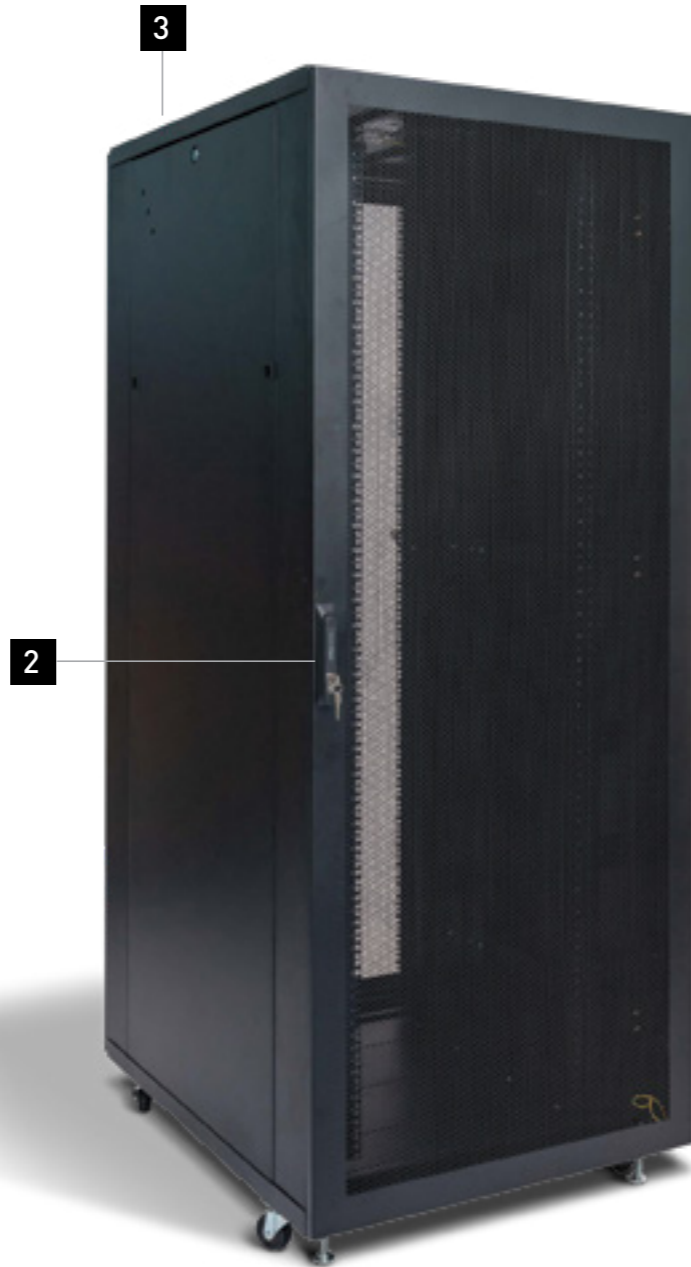

THESE RACKS ARE DESIGNED WITH ADEQUATE SPACE FOR MAINTENANCE PERSONNEL TO EASILY ACCESS THE CABLE INSTALLATION DURING MAINTENANCE.

Special features



HEAVY DUTY CASTOR WHEELS WITH ADJUSTABLE FEET



ROBUST SWING HANDLE LOCK SET
Access control door handles available when high security level is required.

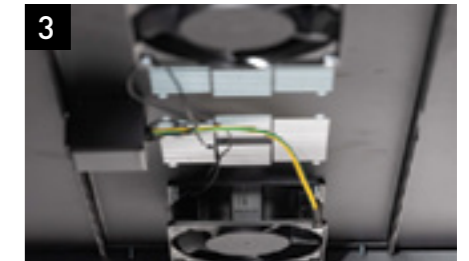

FAN TRAY
Cooling makes up to 70% of total energy costs. Effective cooling strategies can mitigate energy losses which translate into cost savings.

Cable management

Legrand SmartRak accomodates both top and bottom cable entries with multifunctional cable trays to facilitate neat installation within the rack. Available also are accessories such as cable fingers and bobbins.

Efficient routing of cables reduce cost and facilitate ease of maintenance.

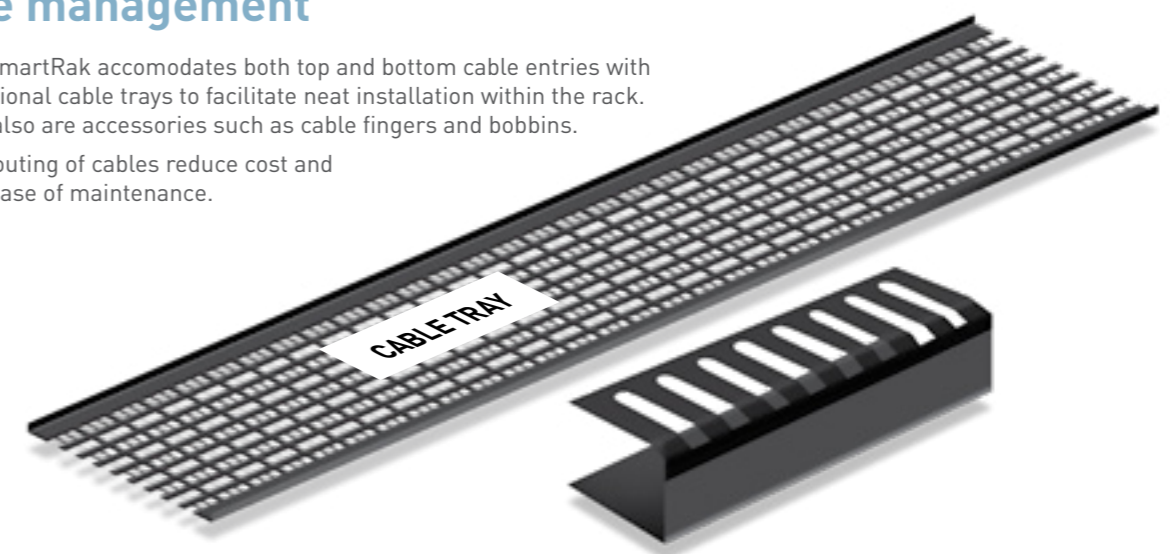

AN OPTIMISED SOLUTION

Legrand SmartRak is an improved multi-purpose rack system that is scalable and flexible for all kinds of data centre and LAN applications. The cabinet is strong and versatile for large cable management from top or bottom.

Racks and accessories are stored in our facility



Enabling faster deployment and more efficient project and resource planning.



HOW QUICKLY CAN YOU REACT TO THE CUSTOMER'S REQUEST?

Legrand SmartRak's are versatile racks that come with a set of standard accessories. They are easy to deploy and install without the need of skilled contractors or specialised tools.

WHAT IS THE EXPANSION ROADMAP OF THE DATA CENTRE?

The investments made today will not see returns in the future if it is unable to meet the changing needs of the customer.

FLEXIBILITY

Safe guard the investment today with racks and solutions that are versatile enough to meet future needs.



Racks can be easily upgraded to connected assets with the addition of access controls, environmental sensors, smart PDUs without retrofitting works that disrupt operations.

Busway

Starline Track Busway

Ideal choice for DC power needs: It's the simple, versatile, fast and economical solution for supplying power to electrical loads. Our cutting-edge engineering gives you the unique ability to instantly tap into the busway at any location, with a variety of plug-in units.

Distributing power & removing limitations

Reliability:
Unique turn and lock connection method.

Constant connection:
The plug-in head can be inserted anywhere along the busway and it is locked in by rotating it to 90 degrees.

Cost saving:
StarLine busways eliminate power interruptions caused by overheating or loss of connection.

Flexible and scalable:
StarLine busway system allows you to relocate power anywhere you need it, and anytime, without shutting down power.

Complete range:
The most popular, powerful and productive systems feature 250, 400, 800 and 1200 A options for power.

Smart investment:
The plus-in units can fit any of the StarLine busways, so that your investment is protected as your power needs change.

Accreditations

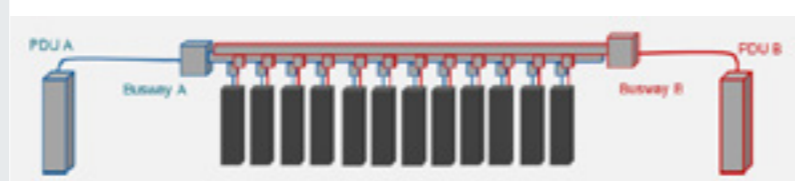

More usable space
More efficient cooling
Less wiring errors

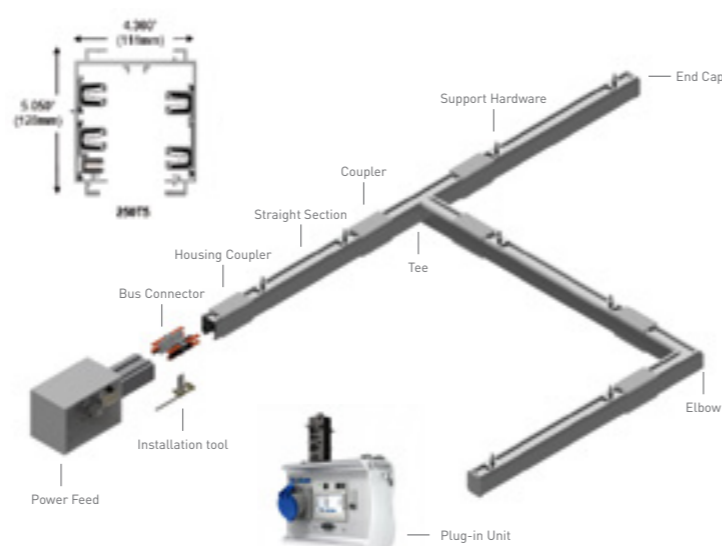

Reduced facility construction costs

Labor savings mean installation costs less
Eliminates costly changes and outside labor costs for electrical specialists
Lower cost of ownership

Faster installation

Building projects are up and running faster
Add, remove or relocate power easily and quickly

Flexibility for the future

Plug-in units can be disconnected and connected without de-energising the busway
Requires no routine maintenance
Faster and cost effective expansion or remodelling



More choices

Scalable and customisable lengths, sizes and configurations to meet your unique specifications
A variety of plug-in units and Starline's monitoring capabilities make us the preferred choice of data centres and mission critical facilities

Environmentally friendly

Less installation materials
Busway and outlets are reusable and relocatable



Simple, versatile, fast

Busway Mr Busbar

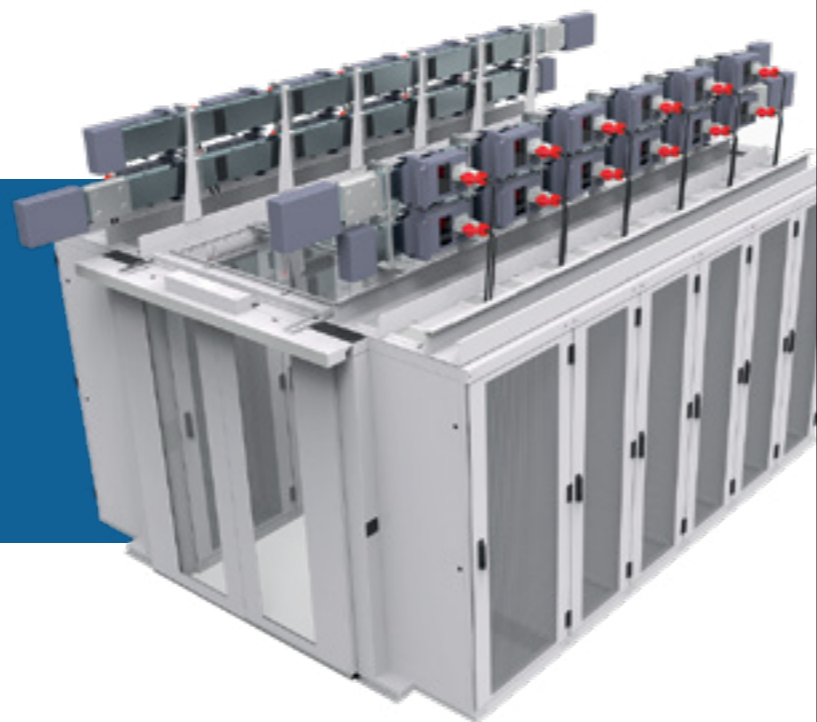

- Medium power: From 63A to 1000A
- MR (Medium rating) Range
- For the distribution of power in the white room of Data Centre
- Available with 600mm or 800mm window pitch for a perfect integration with racks

Different options available:

MR DC: 4 internal conductors (3P+N+PE case)

MRf DC: 5 internal conductors (3P+N+PE conductors)

Painted versions on request

Range:

from 160A to 1000A

Material of the bars:

Aluminium (Al) or Copper (Cu)

Straight elements:

Length = 3m - 2.4m - 1.8m - 1.6m - 1.2m

Outlets = 5+5 / 4+4 / 3+3 / 2+2 (on both sides)

Feed unit + end cover:

Polyester version for 160A and 250A

Metal version for 160A to 1000A

Tap off boxes:

From 32A to 160A (dedicated 2 DC application)

Polyester and Metal versions

Certifications

Zuchinni Busbars come with LOVAG - ACAE certification which is valid all over the world.



Strict Quality Management System according to ISO 9001 with Bureau Veritas approval.



Energy distribution solutions in the computer room

The MR busbar range allows hot swap installation and disconnection of tap-off unit while energised.

Secure power supply to racks

With tap-off boxes, with or without metering

With metering - ideal for colocation DC

Hotswapped enabled: the complete unit can be connected to the power and to the metering bus while installation is energised.

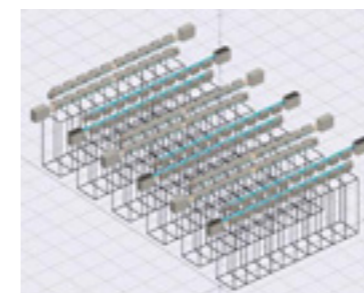
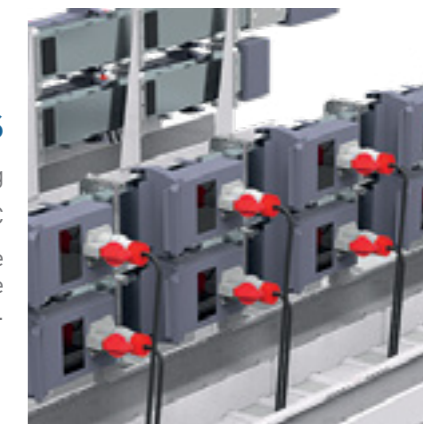

Seamless integration

Seamless integration with Legrand software

Flexible and easy installation

Wide range of tap-off boxes

Dedicated for DC with tap off boxes pitch of 600mm or 800mm

Easy to adapt to type of power supply required (three-phase/ single phase, 16-32-63A)



Tap-off box for MCB's

Tap-off box

Outlet cover

End cover

Horizontal elbow

Vertical elbow



Feed Unit

Perfectly suited to data centre applications

Structured Cabling System

Infinium™ HD-E (Enhanced) Fibre Enclosure

DESIGNED TO SIMPLIFY INSTALLATION AND IMPROVE EXPERIENCE

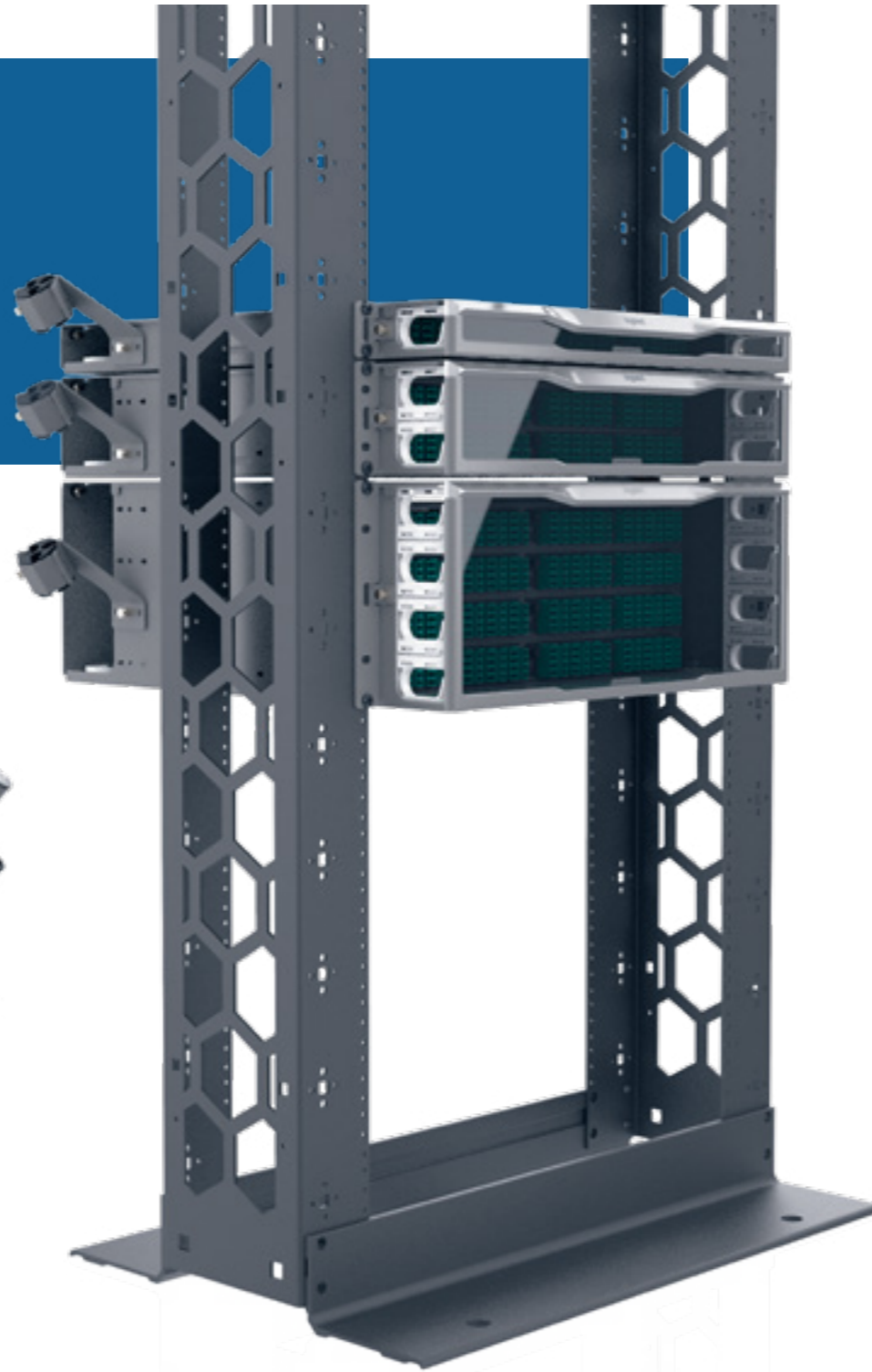

Designed to GROW WITH THE NETWORK

The Infinium HD-E Fibre Enclosure is an ideal solution for fibre networks in data centres and building networks. The high density footprint accommodates up to 96 LC fibres in 1U of rack space. This enclosure has many innovative features designed with the installer, contractor, and network professional in mind, providing a simplified process when installing or working within the enclosure.

- High density, up to 96 LC connectors in 1U of rack space
- Available in 1U, 2U, and 4U
- Accommodates 4 mounting depth positions
- Magnetic door latch
- Versital label card mounting locations (Door or Tray)
- Forward sliding label card
- 60/40 split toolless top cover
- Toolless cable attachment arms
- Pivot arms for fibre slack management
- Magnesium color scheme



1U Enclosure



2U Enclosure



4U Enclosure

Structured Cabling System

Fibre Systems Creating Full HD

Legrand boosts its high density offer for building networks and data centre applications within LCS³ fibre systems. From 1U to 4U, they support the fibre and equipment port density required for all networks with high and even ultra high density (UHD version)

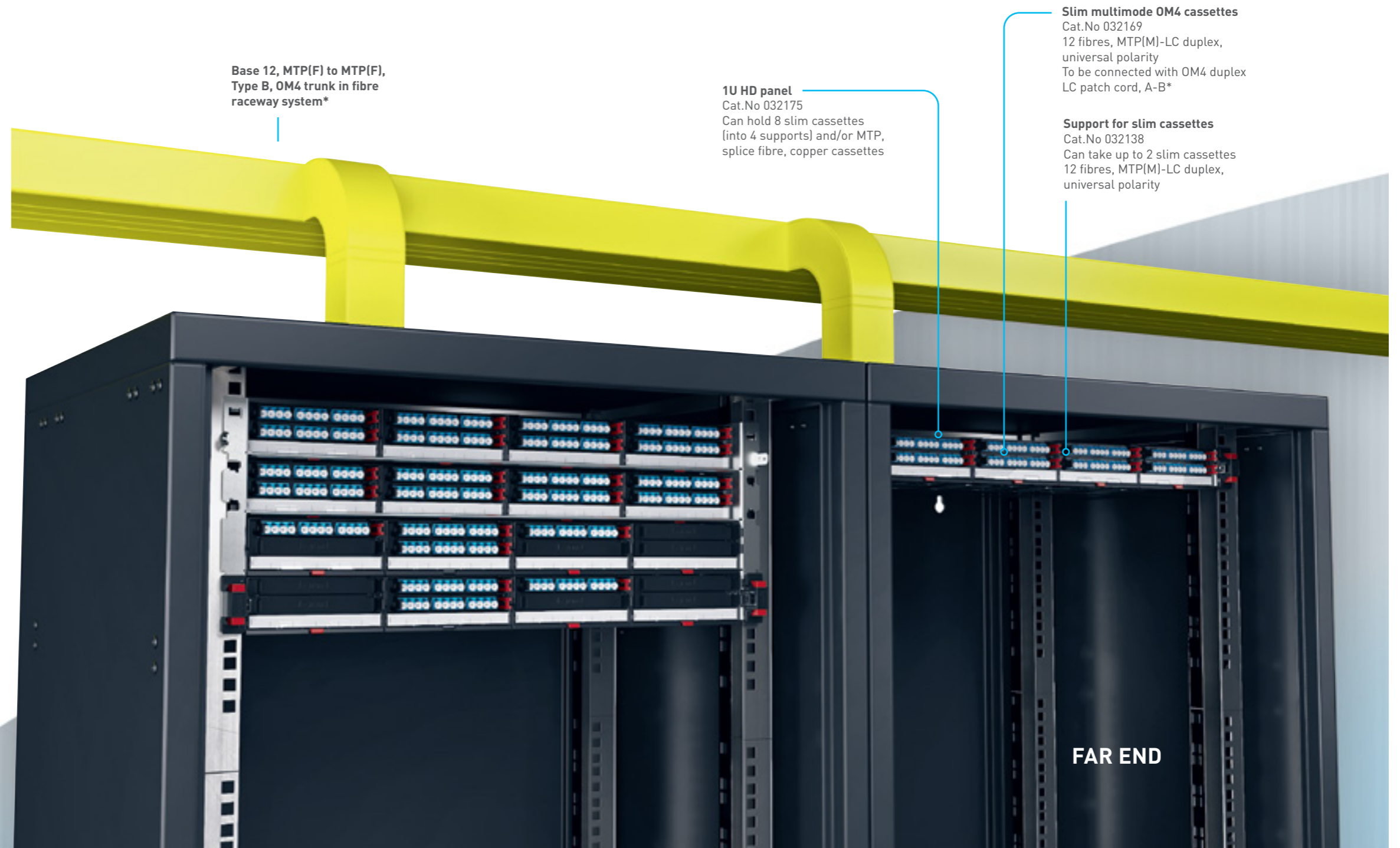

Base 12, MTP(F) to MTP(F), Type B, OM4 trunk in fibre raceway system*

1U HD panel
Cat.No 032175
Can hold 8 slim cassettes (into 4 supports) and/or MTP, splice fibre, copper cassettes

Slim multimode OM4 cassettes
Cat.No 032169
12 fibres, MTP(M)-LC duplex, universal polarity
To be connected with OM4 duplex LC patch cord, A-B*

Support for slim cassettes
Cat.No 032138
Can take up to 2 slim cassettes
12 fibres, MTP(M)-LC duplex, universal polarity

FAR END

Structured Cabling System

LCS³ Ultra High Density Modular Panels

From 1U to 4U

Optimise space and connectivity with our three new HD modular panels. These quick fixing solutions (automatic mounting and automatic grounding on 19" uprights) offer you optimum capacities per U: 96 in LC version, 48 in SC version and 24 in ST version. Keeping link connections accessible and manageable, they offer slim and mix media cassettes.

Rear management accessories to suit all configurations: fan out, cable glands, copper

Possibility to mix fibre and copper cassettes in one panel

Each panel can be equipped with both standard and slim High density cassettes

Quick fixing solutions on all the versions from 1U to 4U

Cord management system (except for the 1U panel, to be equipped with Cat. No 032178) with front, side and bottom protection of the patchcords, preventing any risk of damage

Labeling system for easy identification

Integrated front door for protection against intrusive patching and laser

Equipped with the new generation quick fix system for automatic (screwless) mounting on racks or cabinet uprights

4U HIGH DENSITY PANEL
Can hold up to 32 slim cassettes (into 16 supports)

1U HIGH DENSITY PANEL
Can hold up to 8 slim cassettes (into 4 supports)

2U HIGH DENSITY PANEL
Can hold up to 16 slim cassettes (into 8 supports)



CAPACITY	CAT. NO
1U High density panel	0 321 75
2U High density panel	0 321 76
4U High density panel	0 321 77

Flexibility of installation

Our new high density modular panels offer complete freedom of installation: opt for a top-of-rack or an in-rack installation depending on your site constraints and your infrastructures configuration.

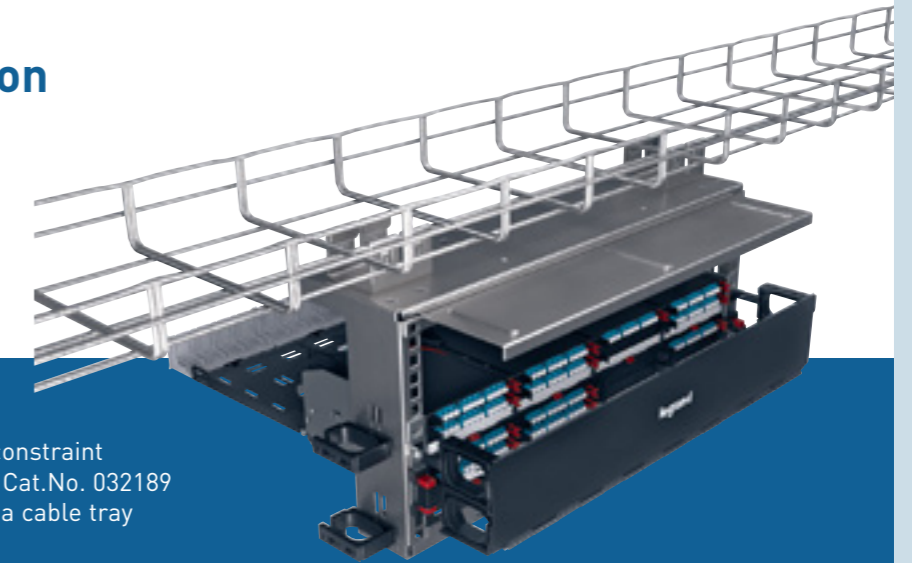

TOP-OF-RACK INSTALLATION

Optimise space and meet any technical constraint thanks to the overhead solution. The kit, Cat.No. 032189 enables you to fix the modular panels to a cable tray (Cablofil) above of the enclosure.

IN-RACK INSTALLATION

Easily mount the modular panels directly into the LCS³ enclosures and equip them with any type of cassettes in order to meet your specific needs.

- 1U, 2U and 4U panels equipped with:
- slim cassettes
 - splice cassettes with 8 MTP adaptors
 - copper cassettes
 - blanking cassettes



UNIVERSAL FIXING

Thanks to the Zero-U kit, you can mount cassettes on 19" uprights, raised access floors, wire and sheet metal cable trays and structural uprights of the enclosure.

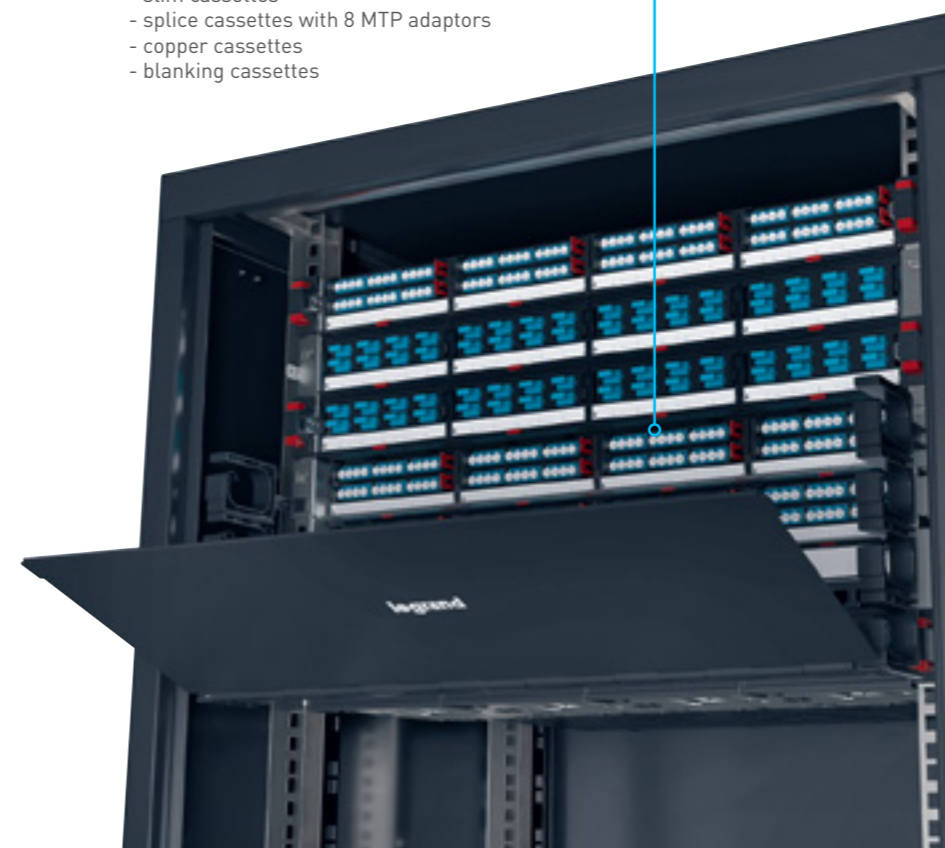

Structured Cabling System

LCS³

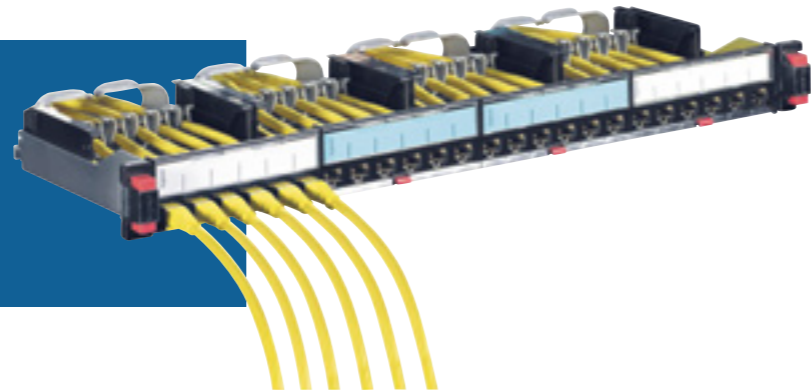

LEGRAND'S COMPLETE GLOBAL SOLUTIONS

Addresses the key challenges for data communication and digital networks. For example; bandwidth, speed and the number of connectors etc.

Structured cabling systems

When describing the performance of a structured cabling system, independently of the technology used for the conductor whether it is copper or optical fibre, the transmission speed is the reference point.

LCS³, the new Legrand structured cabling system, ensures high performance and reliability for the installation via zero fault solutions and routing systems that are ideal for copper and optical fibre cables.



25 years warranty: Terms and conditions apply

Zero fault system

The innovative Legrand LCS³ offer provides you with:

25Gbps and 40Gbps BASE-T Ethernet solutions with the copper system.

40Gbps and 100Gbps Ethernet solutions with optical fibre system.

To ensure the 40/100 Gbps and Fibre Channel protocols are supported, hence opt for LCS³ high speed optical fibre solutions, among which our newest MTP connectors and cassettes. They make for perfect connection in just a few seconds, giving a link providing excellent performance levels, from the patch panel through to the workstation. These solutions can be used to create wiring architectures for the LAN and SAN infrastructures of data centres with OM3 and OM4 performance levels, in multi-mode and OS1/ OS2 in single-mode.

As for LCS³ Cat. 8 copper solutions, they provide performance levels meeting with the 'ISO/IEC 11801 standards - third edition' requirements.

All the LCS³ components are tested individually at the end of production and their excellent performance levels over short links (less than 15m) ensure availability of the bandwidth at the highest frequencies. As for the Legrand RJ45 and optical fibre connectors, their design ensures they comply with the installation regulations: correct installation is thus assured.

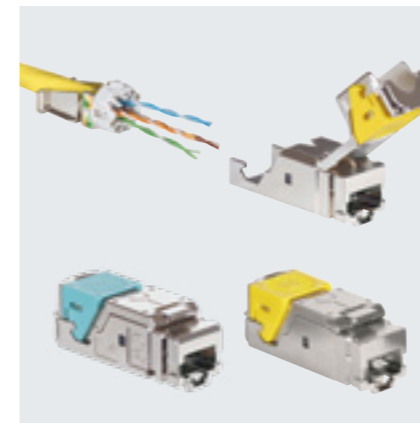

COPPER

Easy installation

The **new toolless connectors** with toolless fast connection are available in all categories for installation both on patch panels and in the workstation

A perfect connection can be obtained in a few seconds, guaranteeing optimum performance of the link from the patch panel to the workstation

Fast colour identification for all categories

Flexibility and easy maintenance

COPPER

Flat and angled solutions

Fast push-button extraction

Sliding cassettes: easier maintenance

Innovative modular cassette system

Easy maintenance: remove connectors without disconnecting the patch cords



OPTICAL FIBRE

Easy to upgrade and to maintain

Modular blocks are easy to add: LC, SC, ST, LC APC, SC APC

Mixture of fibre & copper solutions

Sliding cassette : easier maintenance

Fast push-button extraction

Innovative modular cassette system

Cord protection & guide kit



Meet all bandwidth requirements

144 LC ports per unit UHD - ultra high density - 1U, 2U, 4U

96 LC ports per unit - high density - panels

MTP (multiple fibre push on / pull off compatible MPO)

Speed, resistance, high performance and high density

High performance and reliability

Power Distribution Units Intelligent PDUs

The Raritan PX family of high-quality, intelligent rack power distribution units (iPDUs) offers real-time remote power monitoring of current (Amps), voltage (Volts), power (kVA, kW) and energy consumption (kWh) with +/- 1% billing-grade accuracy, even at the outlet level.

Raritan's PX intelligent rack PDU Series offers more than just power distribution—it's a launch pad for real-time remote power monitoring, environmental sensors, and data centre infrastructure management.

POWER MANAGEMENT - PX INTELLIGENT PDUS



Get the most out of your infrastructure

The Xerus Technology Platform is a combination of hardware and software technologies embedded in all Raritan power solutions. It helps maximise data centre efficiency by delivering military-grade security, high compute power, advanced alerting, and complete visibility into your power chain.



Intelligent field replaceable controller

Industrial grade reliability, configurable firmware, disaster recovery support, and hot swap capability in the event of a malfunction



Dual network access

Infrastructure managers, co-location facility staff, or IT administrators can all see the same critical energy and environmental data provided by your PX, even if they're on different networks or VLANs



Full colour chassis

Raritan's intelligent PDUs are available in multiple colours that help reduce errors, and make it easier to identify power feeds, and troubleshoot, thereby lowering the risk and duration of unplanned downtime

Built-in failover power

Using the expansion port available on some PX models, maintain network connectivity and power between two connected PDUs. Outage alerts lead to faster remediation, allowing you to maintain full control over the peripherals connected to your PDU and devices cascaded downstream

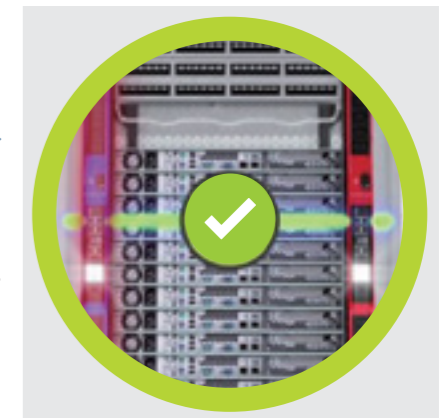

Power Distribution Units Intelligent PDUs



SecureLock™ power cords

The IEC outlets that securely hold plug due to vibration or human error. Raritan's intelligent rack PDUs are equipped with SecureLock outlets that lock when using SecureLock power cords to prevent accidental disconnects

SecureLock outlets

Equipped with SecureLock outlets that lock when using SecureLock power cords to prevent accidental disconnects



	1000 SERIES	2000 SERIES	4000 SERIES	5000 SERIES
Inlet Metering	●	●	●	●
Branch Circuit Metering	●	●	●	●
Circuit Breaker Alarming	●	●	●	●
Outlet Level Metering	N/A	N/A	●	●
Outlet Level Switching	N/A	●	N/A	●

We offer the broadest portfolio of Rack PDU configurations, with the most options for outlet metering
Go to our PDU Selector site: <https://www.raritan.com/product-selector>
To select the Rack PDU that's right for you from 1,000+ unique Raritan models

Data Centre Security at Rack Level

Once inside the data centre, there are still several other layers of security to address. Which server rack door gets opened for who, what audits are in place, what type of door handle locking system is installed, what alerting and visual evidence is there in case someone does access a rack unauthorised? How am I notified when cabinet equipment gets removed and how do I get a visual view of its exact location?

XERUS TECHNOLOGY PLATFORM

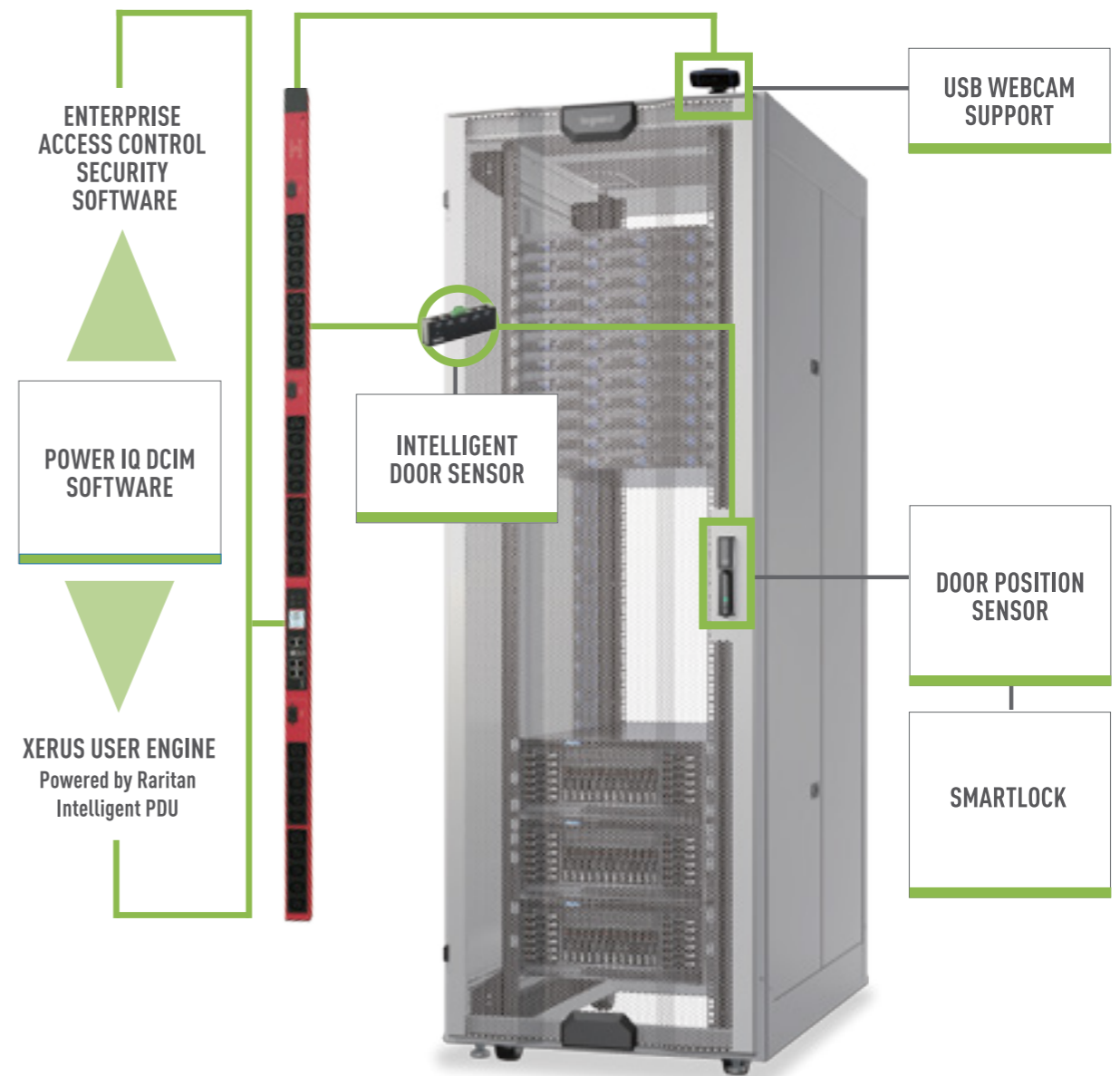

Power Distribution Units

PDU Sensors

Wireless Sensors

Wireless sensors

Linked to intelligent PDUs to control data centre environmental conditions and rack door access.

Features

- Radio frequency technology 2.4GHz (Not WIFI)
- Temperature and humidity (T1H1) sensor
- Contact closure (2 Doors Open/close detection) sensor
- USB 2.0 dongle for pairing
- Mounting brackets for Minkels racks
- Battery powered with green power (One-way power saving protocol)



- PROTECTION AGAINST ENVIRONMENTAL RISKS AND HUMAN ERROR
- EASY DETECTION OF HOT SPOTS AND RISKY ENVIRONMENTAL CONDITIONS
- MINIMUM 5 YEARS BATTERY LIFE ON ALL SENSORS, WITH REPLACEABLE BATTERIES
- SECURE AND RELIABLE INSTALLATION
- HIGHLY ACCURATE ENVIRONMENT MONITORING (+/- 1%) TEMPERATURE/HUMIDITY ACCURACY
- REDUCTION OF COOLING COSTS AND OPTIMISATION OF RACK AIRFLOW DELIVERY
- EASY WIRE-FREE DEPLOYMENT AND MAINTENANCE, WITH VARIOUS FIXING METHODS POSSIBLE
- ENERGY-FRIENDLY RADIO COMMUNICATIONS POWERED BY ZIGBEE GREEN POWER TECHNOLOGY

Plug and play wireless sensors

TEMPERATURE & HUMIDITY



DOOR OPEN/CLOSE

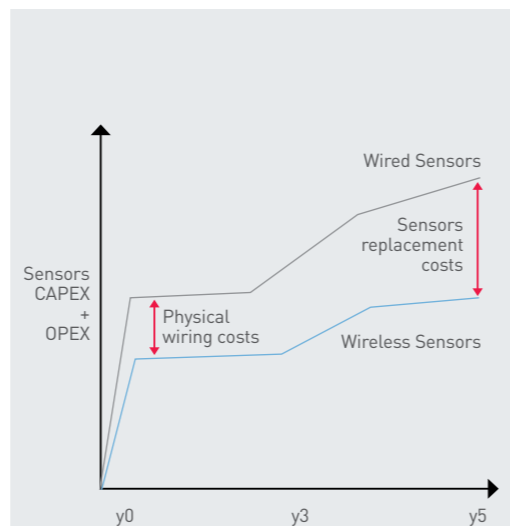

Zigbee peripherals compatible



CONTACT CLOSURE WIRELESS SENSOR (CAT. NO. 646004)

- Manages door contact and alerts in case of door opening/closing
- Enables to:
 - Directly manage and configure alerts inside the PDU firmware
 - Track work orders into the rack
 - Verify if a door has been left open unintentionally



TEMPERATURE & HUMIDITY WIRELESS SENSOR (CAT. NO. 646003)

- Monitor cool air entering and/or hot air being expelled
- Enable to:
 - Optimise cooling infrastructure
 - Efficiently control temperature and humidity levels in order to prevent equipment being damage
 - Reduce energy cost



USB DONGLE (CAT. NO. 646005)



- Directly pluggable to the intelligent PDU
- Plug & Play with Legrand
- Enhance security: Each wireless sensor has a unique encrypted ID (Zigbee Green Power Technology) which prevents the USB Dongle from confusing them with other equipment
- Instantly detects and pairs with available sensors, and aggregated their data into the PDU firmware



Responsive user interface

- Sensor metering at a glance
- Easy to configure and commission through Zigbee device manager feature
- No-fuss peripheral commissioning using hand scanner or CSV file
- Dynamic HTML to support multi devices
- Configurable alerts
 - 4 thresholds per parameter: Measurement above or below priority high or low
 - Alert generation through: Colour (red/yellow) on display



Battery powered with green power (One-way power saving protocol)

Power Distribution Units

Standalone PDUs

SOLUTIONS FOR ANY CONFIGURATION

The standalone PDU offer combines quality and innovation with a wide range of applications. This range integrates seamlessly into any installation ensuring compliance with applicable standards.

CORD LOCKING SYSTEM (C13 AND C19 OUTLETS)

A major addition to the range and exclusive to Legrand, C13 and C19 outlets have a power supply cord locking system which prevents accidental disconnection and guarantees absolute safety.

GENERAL CHARACTERISTICS

- Anodised aluminium profiles:
Light and rigid high-end material
- Modular design:
Expandable outlet and function modules

SAFETY

- High electrical safety rating
- High quality connection
- Outlets equipped with safety shutter

• Cord locking system



POWER SUPPLY

- 16 A to 32 A single-phase or three-phase
- PDUs integrate local and international outlet types



STANDARDS

IEC 60950 - Information technology equipment – Safety

IEC 60297-3 - Dimensions of mechanical structures of the 482.6 mm (19 in) series

IEC 60320-2-2 - Interconnection couplers (C13 and C19) for household and similar equipment

IEC 60884-1 - Plugs and socket outlets for household and similar purposes (France, Belgium and Germany)

BS 1363-2 - British standard plugs and socket outlets

IEC 60309 - Plugs, socket outlets and couplers for industrial purposes

Certification: CE, TSE, CCC

Environmentally-friendly products

Eco-friendly design



An innovative technical solution



Cord locking system

Very easy to identify thanks to the orange buttons next to each outlet

EXCLUSIVE TO LEGRAND

Universal system



Takes all cords for standard C13 and C19 sockets.

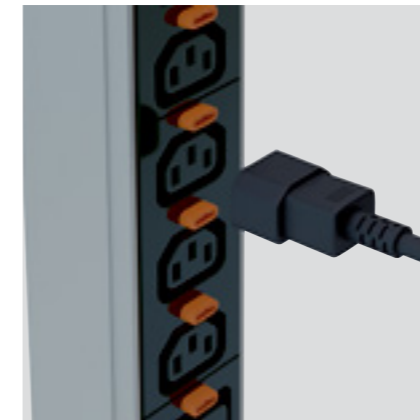

Cord connection

The cord is connected to the socket naturally in one smooth action

Auto locking

Cord held in place

Once the power supply cord is connected, it locks automatically and cannot be removed

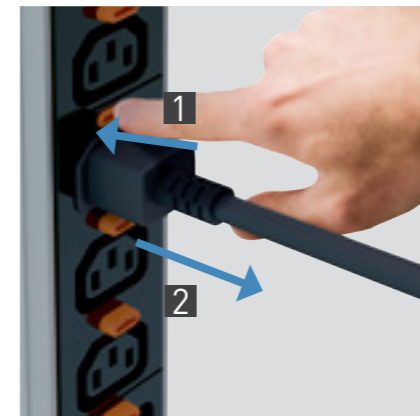

Unlocking

Easy removal

Simply pressing the unlock button releases the cord from the outlet

Rotative cable entry

CABLE ORIENTATION

330° rotatable cable entry for perfect cable orientation and no interference in the cabinet

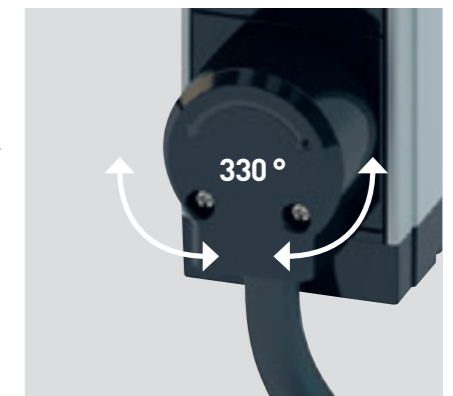

Innovative cord locking system

Server Access PDU Sensors

CENTRALISED

RARITAN'S COMMAND CENTRE SECURE GATEWAY (CC-SG)

Provides IT and lab organisations with secure and consolidated access and power control of all technology platforms at the application, operating system or BIOS level.

CC-SG's single panel of glass helps simplify remote management and expedite troubleshooting of physical and virtual servers, intelligent PDUs, and serial devices.

Available as hardware, VMware or Hyper-V appliances.



Features

Single point of access to physical servers (including blade systems and PCs), virtual machines and VMware® infrastructures

Flexible client options for convenient server access and management of servers and PDUs from an iPhone or iPad

Centralised authentication, authorisation and logging

Intuitive menus and easy reporting - everything from usage and auditing to assets and nodes

Centralised, role-based, user access policy management

Robust security features

High availability and redundancy



Out-of-band KVM and serial access



Raritan dominion solutions

KX III, SX II, KSX II, KX2-101-V2 Rackmount and blade servers network and serial devices
Raritan and Servertech intelligent PDUs

Remote power control



Power IQ integration

Power control of Raritan PX, PX2 & PX3 and Servertech CDU1 and PRO2
PIQ monitoring software integration



Virtual machines



VMware



In-band data centre access solutions

IP Tools	Service Processors
RDP	iLO
VNC	DRAC
SSH	RSA
Telnet	IPMI
Web Browser	IMM

Command centre secure gateway secure,
centralised data centre management

Server Access

KVM-Over-IP-Switch

Dominion® KX III Enterprise IP KVM SWITCH

The Dominion KX III is Raritan's flagship, enterprise-class KVM-over-IP switch that provides 1, 2, 4 or 8 users with BIOS-level, remote management of 8, 16, 32 or 64 servers in a single switch.

With industry leading video performance, security, and reliability, the Dominion KX III outperforms the competition. With standard features such as DVI/HDMI/DisplayPort digital video, VGA analog video, virtual media, audio, smart card/CAC, and mobile access, the Dominion KX III is suitable for both general computer and dynamic broadcast applications.

Available as hardware, VMware or Hyper-V appliances.



Features

- BIOS level remote access and control
- Blazing, high performance audio and video
- Java-free KVM with virtual media
- Military grade security
- Two-factor authentication
- Up to 8 true serial ports
- Remote power control
- Redundancy for reliability
- Remote power control
- Command centre management

ACCESSORIES



User Station

The Dominion® KX III user station is a standalone appliance for high performance IP access to servers connected to Dominion® KX III switches.



Dominion® Serial Access Modules

The two and four port DSAM modules provide true, Java-free serial access to devices such as LAN switches, routers and Linux/Unix servers.



MasterConsole® Digital Cat5 analog/digital KVM switch

Cat5 KVM switches for small to midsize (SMB) IT environments. Ideal for performing system maintenance, administration, and troubleshooting, MasterConsole Digital supports the latest digital video interfaces and analog video, along with stereo audio

MasterConsole® Digital LED integrated KVM switch

LCD console drawers with integrated KVM switch for small to midsize (SMB) IT environments. The product features a 17" LCD drawer with an integrated KVM switch. The digital KVM interface supports VGA, DVI, HDMI, DisplayPort video and stereo audio



LED-backlit LCD console drawer rackmount console drawers

Integrated, 1U console drawers for at-the-rack access of servers and KVM switches in data centres, server rooms, and other space critical environments. 17" and 19" units provide convenient and powerful access and control.

System maintenance, administration,
and troubleshooting

Server Access

Serial Console Server (SX II)

THE DOMINION SX II IS RARITAN'S NEXT-GENERATION SERIAL CONSOLE SERVER

(Terminal Server) that provides IT and network administrators secure IP access and control of serial devices, anytime, anywhere. The new SX II is the most powerful, secure, reliable, easy-to-use serial-over-IP device on the market. SX II provides convenient access to networking devices, servers, PDUs, telecommunications and other serial devices.



Powerful hardware platform for high performance serial access

- Powerful 1GHz CPU engine
- Flash memory, up to 8 GB, for storage and logging
- Dual power supplies and dual gigabit Ethernet LAN ports, with automatic failover
- 4, 8, 16, 32 and 48 port 1U secure appliances (optional telephone modem)

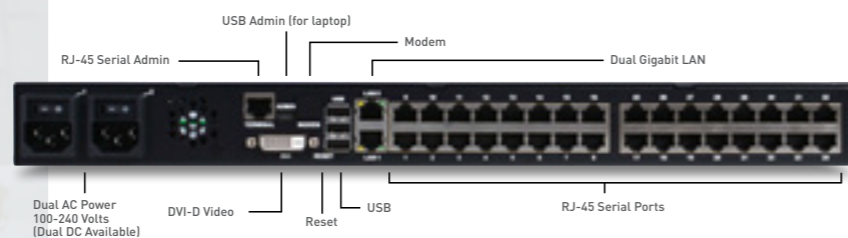

Serial-over-IP access

Complete CLI access and management via SSH, Telnet and web-browser, with convenient direct port access methods. Two script-based automatic configuration methods (TFTP server and USB stick) are available for fast installation and configuration changes. Scales to thousands of devices with Raritan's command centre secure gateway.

Broad serial device support

Enjoy comprehensive serial device access to a wide range of equipment. Support for operating speeds of 1,200 to 230,400 bps with flexible, per-port serial options.

FULL CLI-BASED CONFIGURATION AND AUTO-CONFIGURATION

The SX II offers complete CLI access and management via SSH, Telnet and web-browser, with convenient direct port access methods. Two script-based automatic configuration methods (TFTP server and USB stick) are available for fast installation and configuration changes. Automatic port naming based on hostname.



Secure IP access military grade security

Achieve military-grade security levels, including: strong AES and certified FIPS 140-2 encryption, LDAP/RADIUS/Active directory authentication, and dual stack IPv4 and IPv6 networking.

Automatic DTE/ DCE serial port detection

For fast installations, the SX II supports straight Cat5 connections to Cisco and other compatible RJ45 devices, without rollover cables. The SX II can also directly replace the first generation SX with compatible serial device connections.

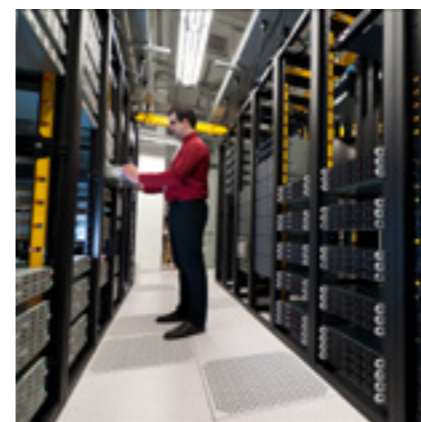

Innovative at-the-rack access

With the Dominion SX II, you get multiple types of local access at-the-rack. This includes: (1) Traditional RJ45 serial port, (2) Mini-USB port for laptop connection, and a (3) DVI & USB-based KVM console for connection to a rackmount keyboard tray, or even a KVM switch.

DOMINION SX II OFFERS MULTIPLE FORMS OF SERIAL-OVER-IP ACCESS

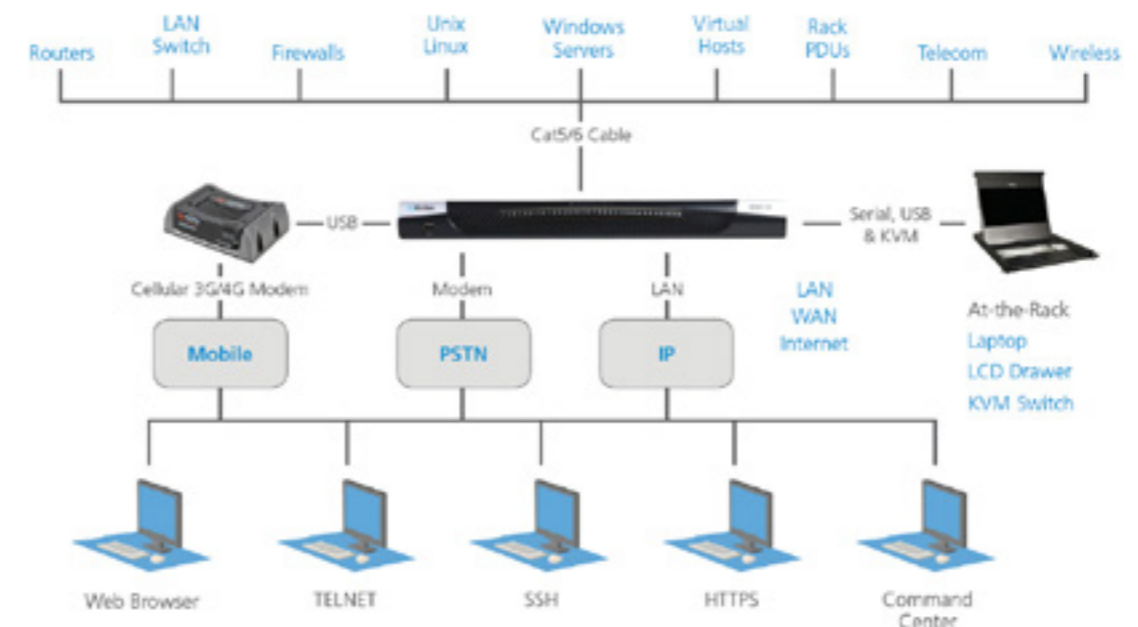

Environmental Sensors

Raritan Smart Sensors

Power consumption is a challenge for many data centre managers. This challenge is further escalated by the fact that many data centres are ineffectively using their current energy resources. Pairing environmental sensors with existing powered and networked resources provide an easy, scalable, and flexible way to monitor data centre conditions.

By leveraging right tools, you are able to:

Prevent server malfunction:

Maintain optimal operating temperature for IT devices

Optimise energy usage:

Identify when you are overcooling or undercooling



RARITAN SMART SENSORS

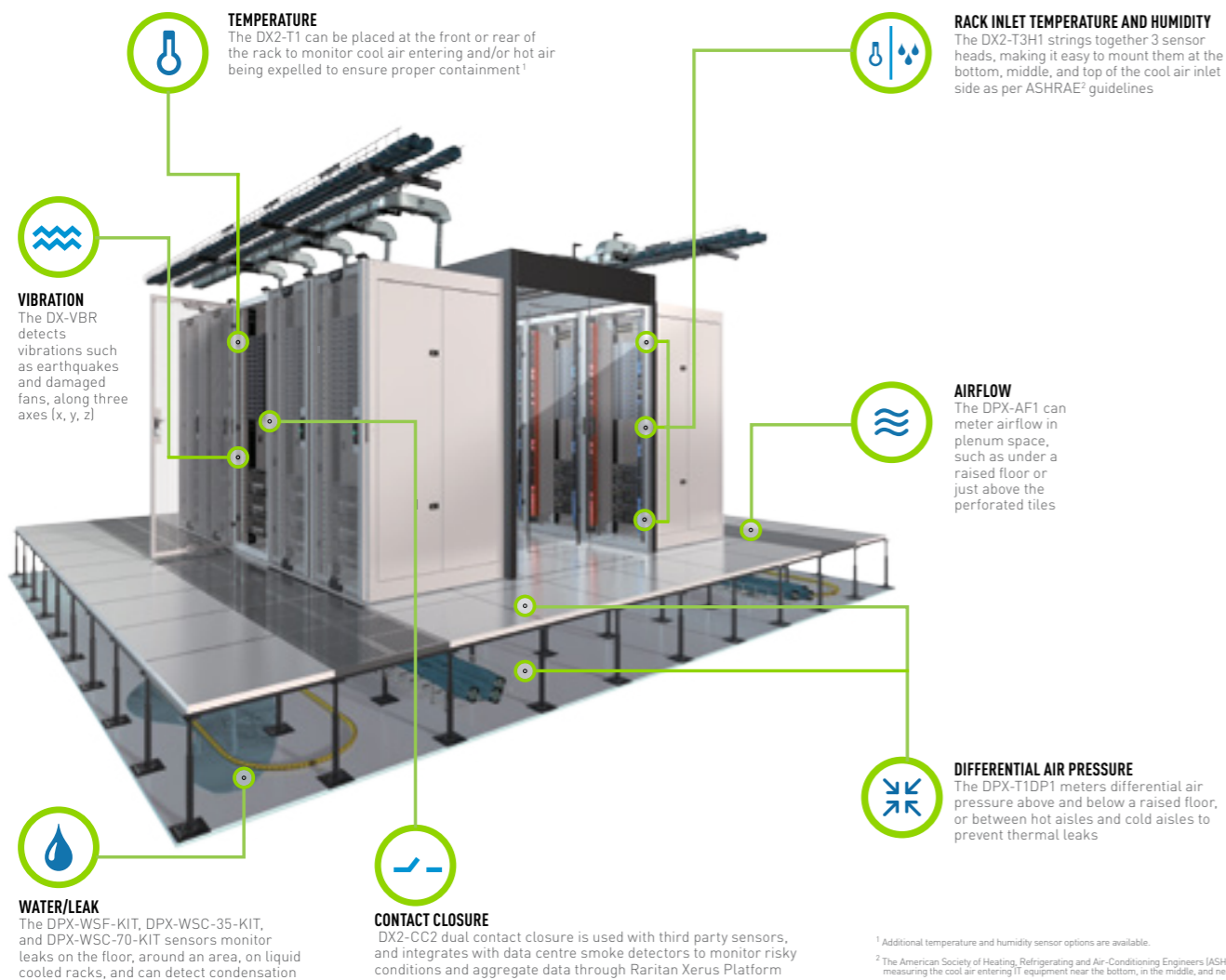

¹ Additional temperature and humidity sensor options are available.
² The American Society of Heating, Refrigerating and Air-Conditioning Engineers (ASHRAE) recommends measuring the cool air entering IT equipment near the bottom, in the middle, and near the top of each

Smart Rack Controller

SENSOR MANAGEMENT SOLUTION



A TOTAL SOLUTION TO MANAGE ALL ASPECTS OF YOUR RACK ENVIRONMENT

REMOTE HUB PORTS

Utilise these ports to connect two Remote Hubs, providing access to 8 additional sensor ports. Each hub and its connected sensors can be located up to 50m away from the device, expanding coverage to where you need it

iX7 CONTROLLER

The iX7 controller provides a future-proof design with more computing power, higher efficiency processors, a host of extra ports, and standard Gigabit Ethernet



DUAL POWER SUPPLY

Dual power supplies and inputs provide true power redundancy. If one feed loses power, you won't lose power to the device

SENSOR PORTS

- Environmental sensors**
- Temperature
 - Humidity
 - Dual temp/humidity
 - Airflow
 - Differential air pressure
 - Water floor leak
 - Water rope

Physical access & security sensors

- Contact closure
- SmartLock
- Proximity

Specialised Sensors

- Vibration

USES AND APPLICATIONS

The SRC's universal mounting bracket allows it to be installed in a vertical or rackmount position. It is designed to meet the standards and needs of data centres, labs, network/compute closets, or remote locations like colocation, POP, and telecommunication sites.

Popular applications include:

- Data centres
- Edge compute locations
- Modular data centres
- Older data centres being refurbished and refitted with newer systems
- 5G installations
- Macro cell towers
- Commercial broadcast radio and TV antenna installations
- Smart city data gateways

BENEFITS

- Minimise the hours needed to track IT assets, thereby saving time and money
- Ensure uptime by monitoring racks for possible hot spots
- Save on cooling costs by confidently raising data centre or facility temperatures
- Maintain cabinet and enclosure security with USB peripherals and contact closure sensors
- Improve data centre uptime by receiving environmental alerts
- Optimise strategic and tactical decision making for the IT environment by tracking IT changes and growth in real-time
- Gain audited controlled access to sensitive IT assets with the SmartLock door system
- Available in 100-240VAC and +/- 48VDC power options

Access and Control Caging

MODULAR SUITE SYSTEM

The modular suite addresses the requirement for a complete modular system that enables the effective and secure segregation of customers and equipment, while retaining unlimited scalability. A range of three panel widths allows limitless combinations, and the use of standard components makes rapid expansion a simple process. It is available as a standard with vented panels and a lock sliding door. Other locking options can be specified, catering to all levels of security requirements.

Additionally, the modular suite can be manufactured in your chosen corporate colour. It has been designed and only requires small number of components with our professional team to complete any installation very rapidly.



Features

- Height:** 2.4 metres or customised height
- Panel widths:** 300mm, 600mm and 900mm
- Gap from floor base of panels:** 25mm
- Colours:** Black/ white
- Standard vented panels or customised**
- Standard sliding door with lock device**
- Optional key and electronic locking systems**
- Rapid and professional installation**
- Modular design, easily expandable**

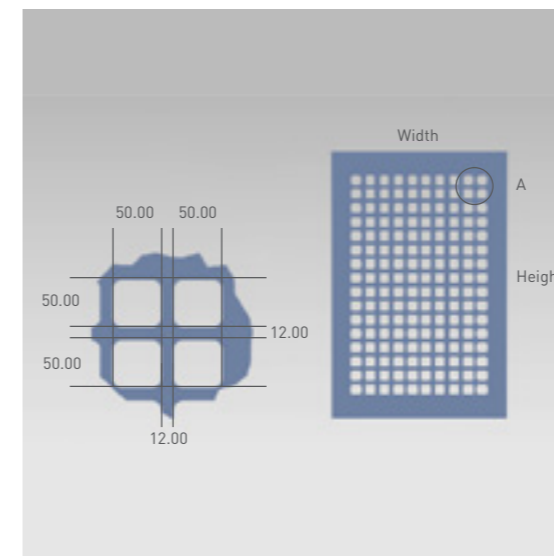

Standard component for limitless combinations

Square hole pattern

Modular solutions for installation

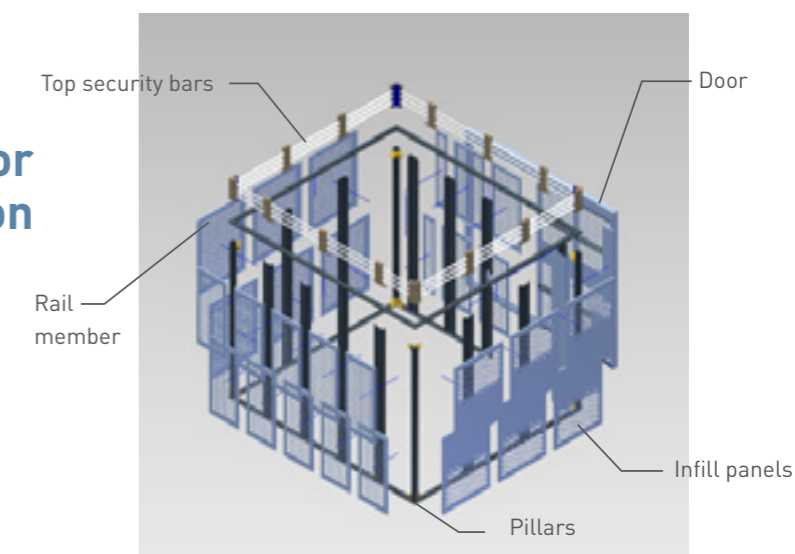

Facilitates integration and maintenance

Access and Control

Smartlock Door Access Control

RARITAN'S SMARTLOCK

An electronic door access and control system which provides an easy to deploy and economical networked locking solution for all types of data centre enclosures. It is a cost-effective, universal solution that addresses evolving security requirements for IT applications and regulatory compliance from HIPAA, SOX, PCI DSS 3.2, or SSAE 16.

The SmartLock system is compatible with Raritan's PX intelligent PDUs and EMX which eliminates the need for expensive installation and a complete separate door locking system. To allow seamless crucial data delivery to DCIM and security software, the SmartLock system easily connects to the PX plug and play sensor.



EASY TO DEPLOY / RETROFIT

Universal lock footprint, easy to retrofit in any existing rack door.

Pre-configured to be recognised by PDUs for rapid deployment across your entire data centre.

SMART CARD COMPATIBLE

Compatible with proximity card readers that use the following technologies: iClass(R), MIFARE(R), DESFire (R), HID(R) Prox, Tag-it(R) and I-Code (R).

The smart card data is also secured by using the AES-128 encryption algorithm.



ELECTRONIC DOOR HANDLE



XERUS FIRMWARE



INTELLIGENT DOOR SENSOR



POWER IQ DCIM SOFTWARE



PX INTELLIGENT RACK PDU



Scalable and flexible

PX intelligent PDUs compatible



Real-time sensing and alerting

Network controlled access



Minimise the risk of downtime with reliable network infrastructure

Access and Control Future Ready Rack

RACKS NOT ONLY ORGANISE IT EQUIPMENT

They provide standardised assemblies that make efficient use of space and security.

IT managers are no longer the only ones wanting to integrate the functions within the rack, Facility and Colocation managers are seeking for CCTV, access control and physical security options within the rack.

Legrand future ready rack design allows customers to extend their investments in rack infrastructure for current and future needs.

THIS IS DONE BY SUPPORTING:

- Different rack PDU mounting options
- Concealed cable paths for SmartLock and sensors
- Optional pre-installed access control and SmartLock from factory
- Optional pre-installed environmental sensors
- Pre-cut panels for future environmental sensors needs

The design



Side View

- Space for mounting rack PDU
- Up to six in one rack
- Accommodates long rack PDU and double wide rack PDU

Top View

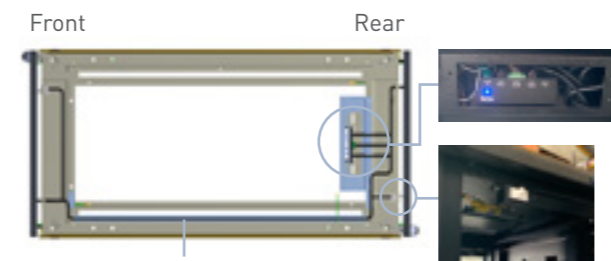

Concealed cable paths for SmartLock and sensors

Basic future ready rack (EZ-KIT-SRC) come with: 1 x smart rack controller 1M LCS3 UTP cable

Future ready upgrade	Security upgrade	
EZ-KIT-SRC	EZ-KIT-UPGD-S	EZ-KIT-UPGD-SC
1 x Smart rack controller with dual network, dual power and sensor connections supporting future rack or containment needs 1 x LCS3 UTP cable to connect a sensor or integrate with another supported accessory	1 x Pair of electronic swing handles with card reader 1 x Pair of door contact switches 1 x Door controller 2 x RFID access cards	1 x Smart rack controller with dual network, dual power and sensor connections 1 x Pair of electronic swing handles with card reader 1 x Pair of door contact switches 1 x Door controller 2 x RFID access cards
Upgrade to EZ-KIT-UPGD-S and / or EZ-KIT-UPGD-ENV	Requires EZ-KIT-SRC or an existing Legrand, Raritan or Servertech programmable rack PDU running Xerus, can upgrade to EZ-KIT-UPGD-ENV	Can upgrade to EZ-KIT-UPGD-ENV
Environmental monitoring upgrade		
EZ-KIT-UPGD-ENV		
1 x Temperature sensor 1 x Humidity sensor 1 x LCS3 UTP Cable to connect sensors		
Multiple EZ-KIT-UPGD-ENV can be connected to one EZ-KIT-SRC or EZ-KIT-UPGD-SC		



SmartLock basic

Easy introduction to rack access control

The SmartLock basic provides the best value for entry level access and control requirements. The standard lock and modular card reader makes this solution ideal for data centres with a smaller footprint



SmartLock standard

A perfect fit for your enterprise security standards

The SmartLock standard is the ideal option for people that require a higher level of security but still want a solution that can be easily integrated into their existing IT infrastructure



SmartLock advanced

Versatile and scalable access control

The SmartLock advanced is the ultimate solution for data centres that require the most secure environment. This option was built to handle future growth demands and security requirements.

Intelligent door sensor

Native support for Weigand protocol

Third party handle/reader capable

Serial interface for future upgrades

Compatible with PowerIQ DCIM software



Cable Management

ENGINEERED CABLE TRAY FOR exceptional performance

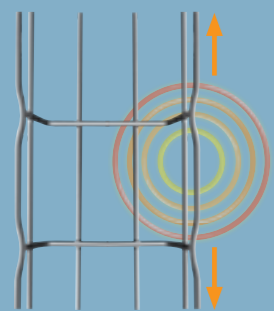

WIRE MESH TRAY WITHOUT EQUAL

The steel structure of Cablofil tray reduces Electromagnetic Interference (EMI) and stray static charges



Fact

Improving airflow around cables and servers increases reliability.

84% OF DATA CENTRES HAD ISSUES WITH POWER, SPACE AND COOLING CAPACITY THAT NEGATIVELY IMPACTED BUSINESS OPERATIONS.



Managed cables for better reliability

Specially designed brackets to provide cost-efficient, more compact alternative to ceiling suspended cable management

Exceptional performance

Drop out accessories for fibre cabling drops with wide radius bends for optimal signal efficiencies

Coordinated powder coating of cable tray and physical infrastructure creates a professional appearance and allows for colour-coded cable pathways

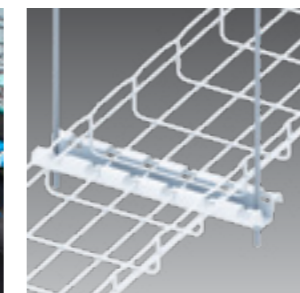
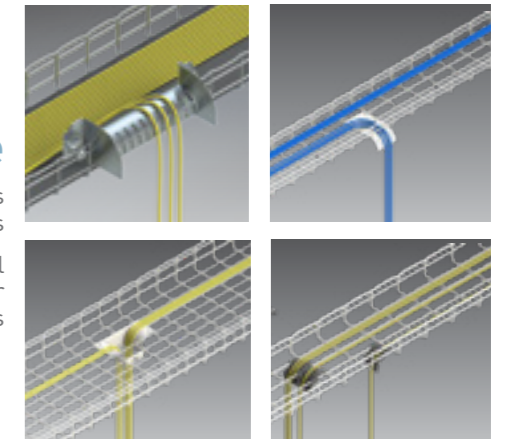

Easy to install supports

Multiple cable pathways are compact with easy access to cables

FAS (Fast Assembly System) secures tray without additional hardware

Cabinets and cable management with a cool factor

Cable Management Cablofil

CABLOFIL MAXIMISE YOUR SERVER ENVIRONMENT

Data centre design is rapidly changing with the newest trends being seen in cloud and colocation server facilities. Increasing server densities, use of fibre optic cables and overhead cabling practices are requiring more modular facility design solutions.

Legrand solutions are designed to keep you ready for the next wave of technology.



Fact
 DATA CENTRE OUTAGES COST
 NEARLY USD **\$12,124**
 PER MINUTE WITH MAXIMUM
 DOWNTIME COSTS INCREASING
 81% SINCE 2010 TO A CURRENT
 HIGH OF USD **\$3,246,915**



Maximise space

Cable tray and networking racks are integrated for better space efficiency and effortless installation

Future ready

Coordinated cable pathways for better logic and appearance that make future upgrades simple

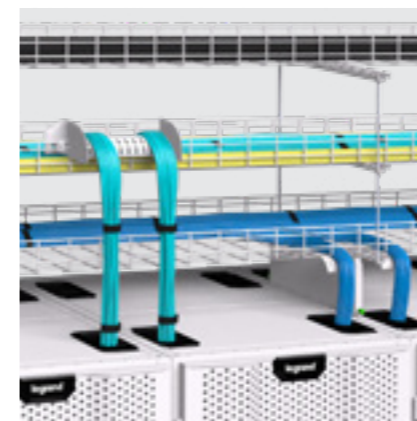
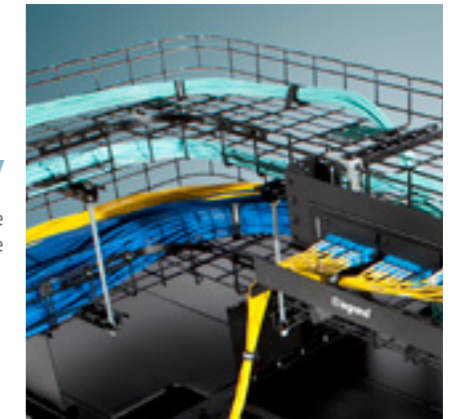

Fibre-friendly reliability

Proper support and protection for fibre optic cabling increases reliability with engineered cable drops, covers and liners

Superior looks

Coordinated powder coating of cable tray and physical infrastructure creates a professional appearance and allows for color-coded cable pathways



Minimise the risk of downtime with
reliable network infrastructure

Cable Management Fibre Raceway

A DEDICATED PATH FOR AN EFFICIENT INSTALLATION

The Legrand Group boosts its offer for data centres with its innovative LCS³ Fibre Raceway system! Dedicated to digital data distribution, the Fibre raceway cable tray is the ideal solution to ensure an optimal optical fibre cabling and a **highly efficient network at all times**

Around half of today's network problems are caused by inadequate cabling infrastructure. With Fibre Raceway, you are sure to benefit from a **reliable, durable and scalable infrastructure**, enabling you to efficiently isolate and protect your fibre optic cables! Besides, Fibre Raceway is a flexible and modular system that allows work to be done quickly on the network with minimal disconnection times.

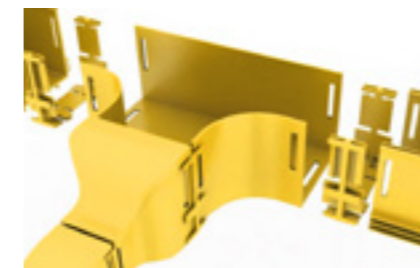
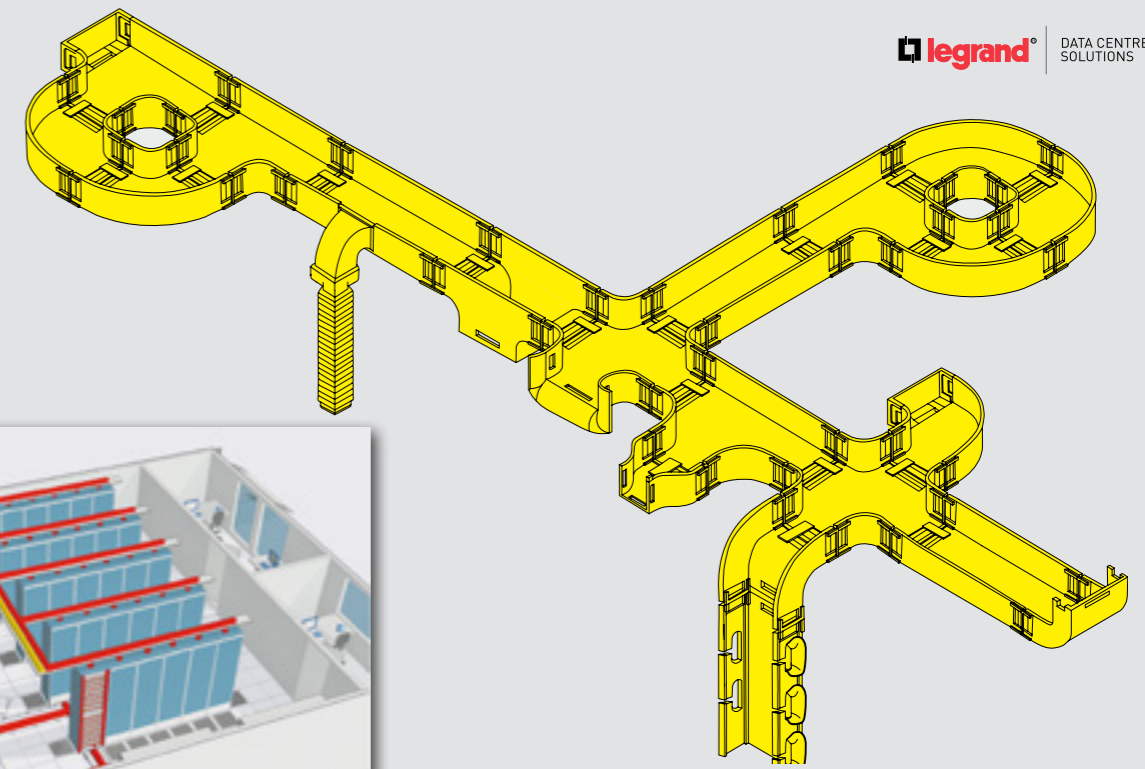
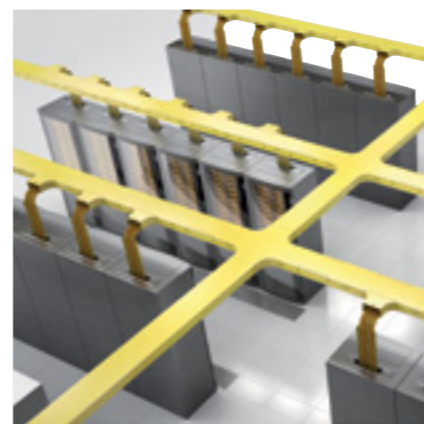
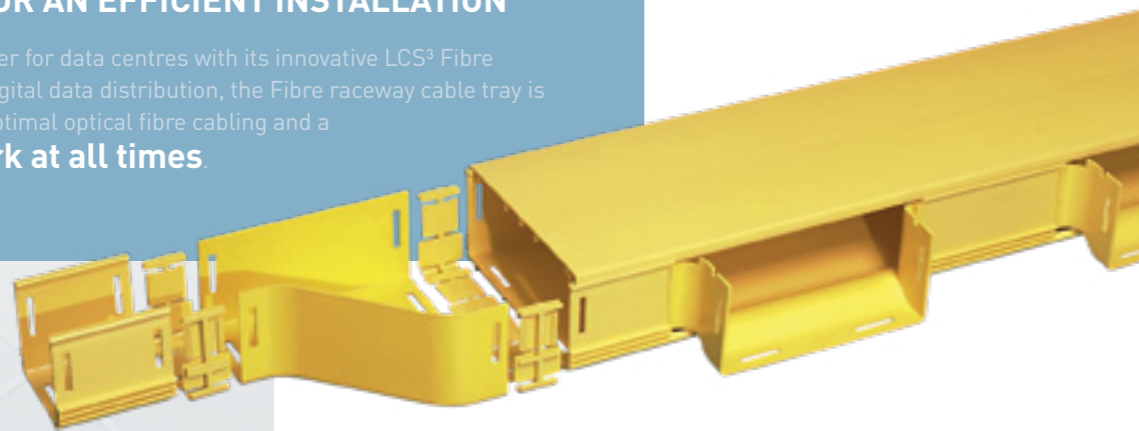

Easy installation

7 basic elements



1. CABLE MANAGEMENT SYSTEM

With the strong growing demand of fibres, fibre cords need to be segregated from copper services and routed in an enclosed duct raceway system, fulfilling following demands:

- Bright distinctive duct color: Yellow
- Protection against compression
- Protection against bend radius
- Available sizes 50 mm, 100 mm, 220 mm, 300 mm and 600 mm

2. MEETS IMPORTANT STANDARDS

- Low smoke zero halogen, self extinguishing. Avoiding risk of harming staff and transmission equipment
- UL94-V-0 (50 mm UL94-V-1) rated
- ROHS Compliant
- UL2024A standard rated

3. EASY & TIME SAVING INSTALLATION

Pre-slotted duct and accessories simply snap together with slotted or slotless joiners, express outlets, break out kits.

4. ZERO DOWN TIME

Fibre Raceway can easily be changed or extended without the need to remove the existing fibre or shut down.

5. FULLY RECYCLABLE

The granulate Noryl used for Fibre Raceway is fully recyclable (cradle to cradle). Very important issue for future data centres.

Configure your system using 7 elements

Industrial Plugs and Sockets

P17 Tempra Pro

ALWAYS ENSURING CONTINUITY OF SERVICE

By updating its ranges of industrial sockets, Legrand is meeting the expectations of professional users.

New benefits in terms of safety, implementation, design and ergonomics guarantee the longevity of this family of products, which has already proven itself over time.



A transformed range which harmonises with the Legrand industrial sockets range

Sockets for internal and external use, protected against projections of water (but not EXPOSED to DIRECT jets)

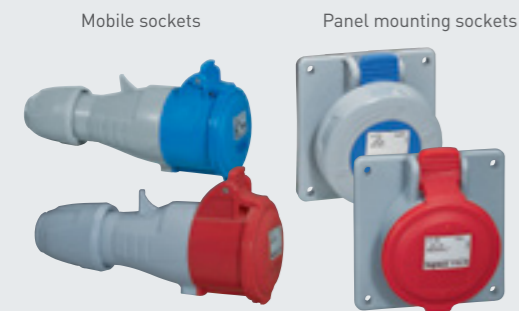

- 2 P+ E / 3 P+E / 3 P+N+E
- From 100 to 500 V
- From 16A to 125A
- 50/60 Hz
- Screw connection

Safety and environment

SAFETY

Connection terminals compliant with standards IEC 60 309 1 & 2

Very high resistance to chemical products. Plugs and sockets made of polyamide 6

Anti-corrosion treated screws, stainless steel springs for the socket covers

Resistant to temperatures of -25°C to +40°C

ENVIRONMENT

Halogen-free recyclable materials (silicone, PVC) for IP44 products

Grouped packaging in boxes

PEP products (Eco Passport)



DESIGN COMPLIANCE

IP44 according to IEC 60529

IK09 according to IEC 62262

Material: Polyamide 6

Self-extinguishing: 850°C (support of active parts)

650°C (plastic housing)

2 mounting positions*

To solve the problem of limited space, the surface mounting sockets offer 2 different mounting positions (5° or 25°) which allow users to adapt to the space available without changing the box

*From 16A to 125A

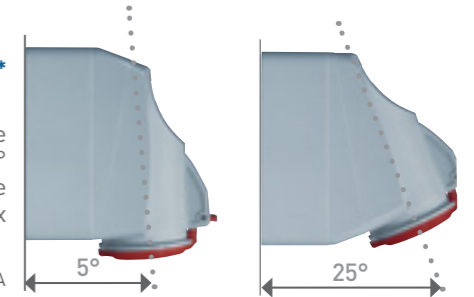

Cable grip

Captive cable grip with anti-vibration system holds the cable in place permanently

The 63 and 125 A products are also equipped with a locking screw

Opening lever

For easier connection /disconnection. Cover held open on panel sockets and surface mounting sockets

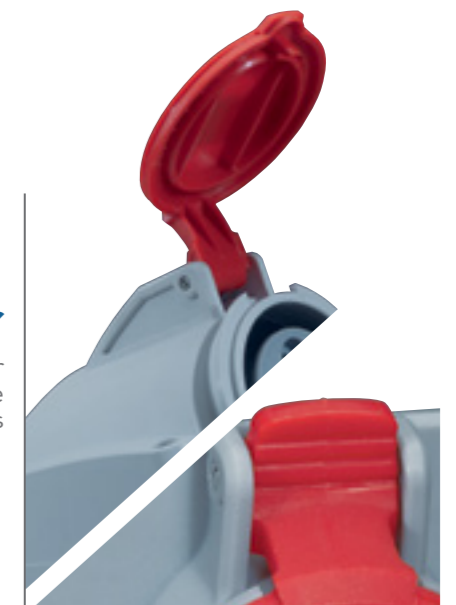

Innovative design

Power Meters

THE ENTIRE ENERGY MANAGEMENT ON A SINGLE PLATFORM

- CX3 EMS

Set
Set the system with functions that are customised to your needs.

Configure
Programme all devices locally and remotely to be able to dialogue both with them and with other external systems.

Supervise
Monitor and control all processes by means of IT instruments to optimise energy consumption anytime, anywhere.

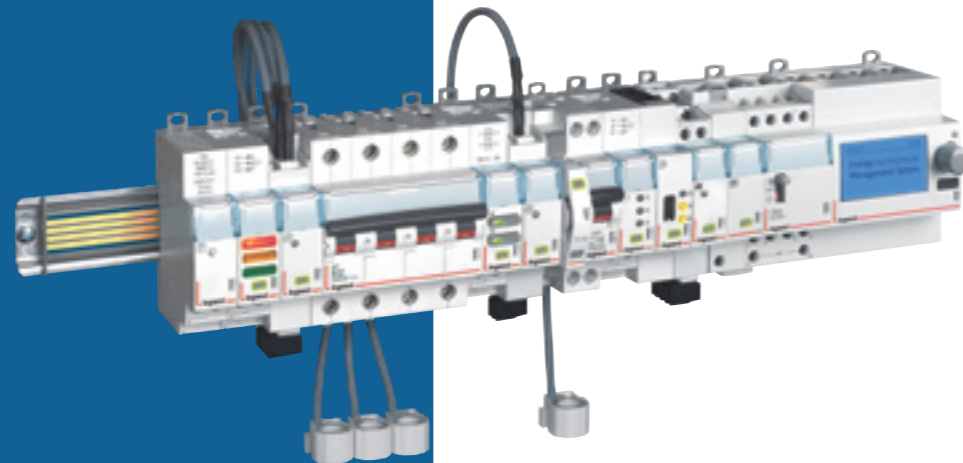

Control your installation in only a few steps:

Register
Register the consumption of all the users of the installation.

Measure
Measure analogue or electrical magnitudes (current, voltage, power, etc).

Signalling
Display the status of electrical protection devices or circuits, both locally and remotely.

Control
Operate electrical protection devices or motorised controls, both locally or remotely by means of manual or automatic actions.

Communicate
Send all information remotely, from the electrical switchboard.

Display
Display the data locally or remotely, on built-in screens, PCs, smartphones or tablets with an Internet connection.



Complete & compact

The system is made up of DIN35 modules that offer maximum compactness in the installation. It is able to offer all the functions for a complete plant supervision.

Simple

Simple to choose
Simple to install
Simple to configure



Adaptable

For every breaker and control devices

Offer consists of UNIVERSAL modules for use with modular, moulded case and power circuit breakers.

For new and existing boards

Use less space in new boards and possibility to upgrade existing installations. Making maintenance easy and more cost effective.

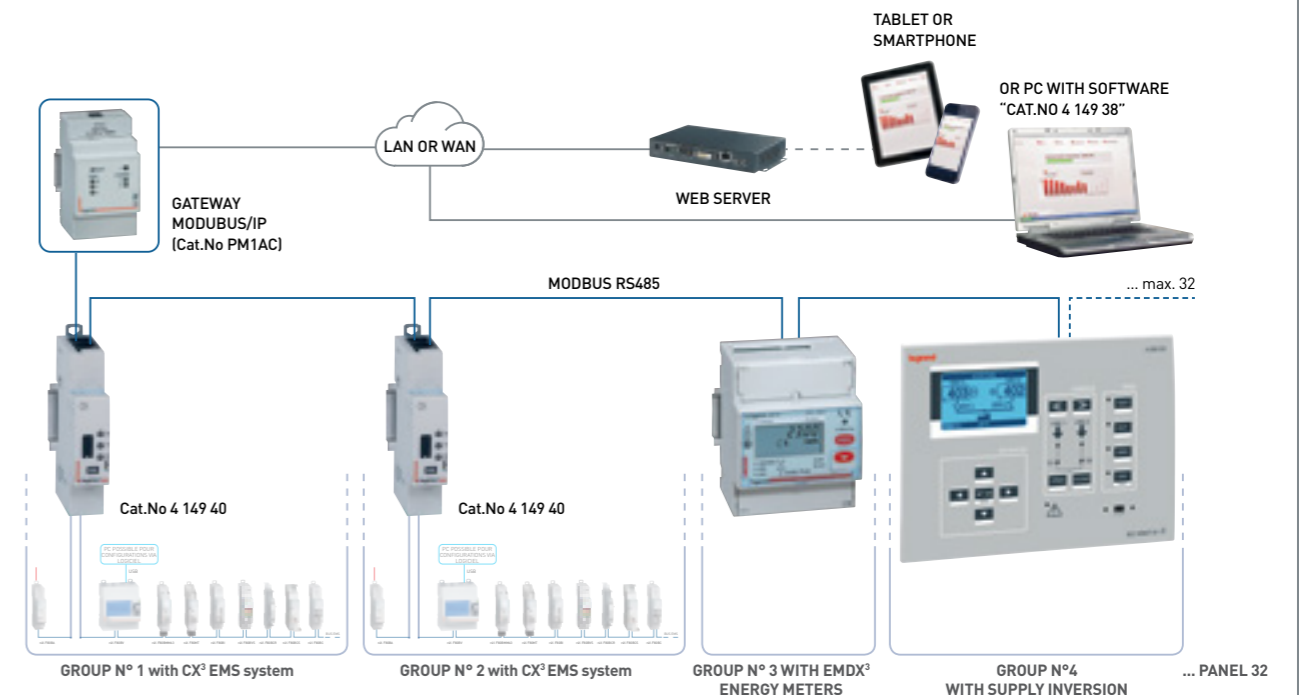

Motion Sensor & Lighting Management Solutions

ENERGY EFFICIENCY AND OPERATING PERFORMANCE

In our range, you are sure to find the Motion or Lighting Management sensor that will suit any data centre area and control your lighting efficiently.



Recommended choice for DC

Quick, easy mounting

Precise detection and settings

Automatic On/Off

Dual technology

Configuration via configuration tool

Light level threshold: 0-1275 lux

Adjustable time delay:
10 sec – 10 min (motion sensors)
0 – 59 min 59 sec (lighting management sensors)

3 wires – with neutral

Incandescence ⁽¹⁾ 

Halogen ⁽¹⁾ 

Fluorescent ⁽¹⁾ 

CFL / LED ⁽¹⁾ 

False ceiling mounting

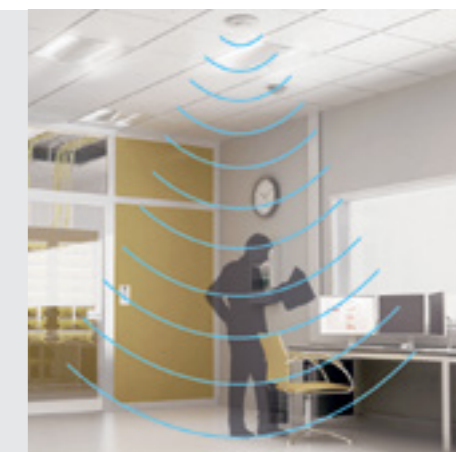
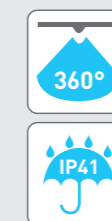

Wall mounting

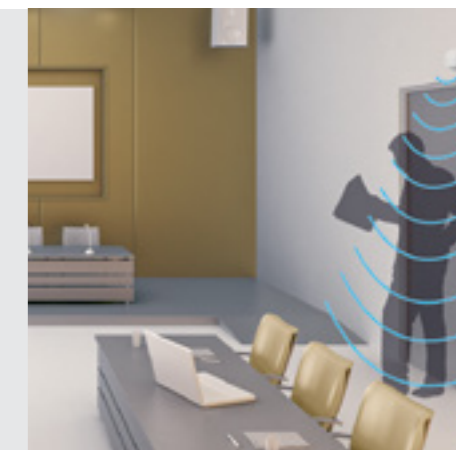

Wall & ceiling mounting

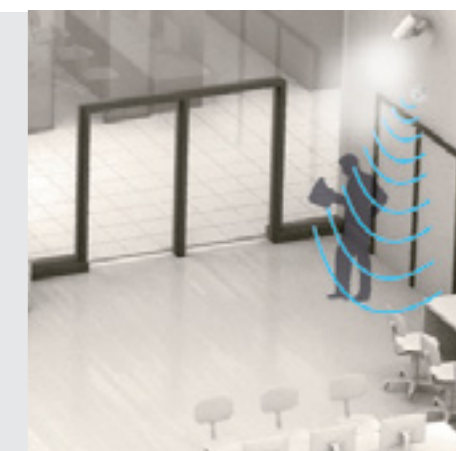
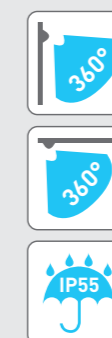

More information?

For detailed product information, refer to the complete range of brochures & websites below



Legrand Australia
Tel.: 1300 369 777
www.legrand.com.au

Legrand New Zealand
Tel.: 0800 476 009
www.legrand.co.nz



FOLLOW US



www.facebook.com/LegrandAustralia



au.linkedin.com/company/legrandaus



Legrand Australia

Building 4, Nexus Industry Park
43-47 Lyn Parade, Prestons NSW 2170
Tel.: 1300 369 777
www.legrand.com.au

Legrand New Zealand

106-124 Target Road
Glenfield, Auckland 0627
Tel.: 0800 476 009
www.legrand.co.nz